

# Optima

## Distribution Class (PDV) and Riser Pole (PVR) Surge Arresters



**HUBBELL**<sup>®</sup>  
Power Systems



NOTE: Because Hubbell has a policy of continuous product improvement, we reserve the right to change design and specifications without notice.

©Copyright 2010 Hubbell Incorporated

**Table of Contents**

|   | Page  |
|---|-------|
| Warranty .....  | 31-2  |
| Introduction .....                                      | 31-3  |
| Distribution Surge Arresters .....                      | 31-3  |
| Alloy ESP Housing .....                                 | 31-3  |
| Basic Construction .....                                | 31-3  |
| Benefits .....  | 31-3  |
| Tests Verify PDV/PVR Arrester Design .....              | 31-4  |
| Full Scale Fault Current Tests .....                    | 31-4  |
| Design Test Report Summary .....                        | 31-4  |
| Optima Design Improvements .....                        | 31-4  |
| Disconnecter.....                                       | 31-4  |
| PDV/PVR   |       |
| Selection Considerations.....                           | 31-5  |
| Temporary Overvoltage.....                              | 31-5  |
| TOV Curve Without Optima .....                          | 31-6  |
| TOV Curve PDV100-Optima .....                           | 31-6  |
| TOV Curve PDV65-Optima .....                            | 31-7  |
| TOV Curve PVR-Optima .....                              | 31-7  |
| Mounting Hardware                                       |       |
| How to Specify a 7XXX Code Suffix .....                 | 31-8  |
| Options Table.....                                      | 31-8  |
| Insulation Coordination/Protective Margin.....          | 31-9  |
| Electrical Characteristics.....                         | 31-10 |
| Physical Characteristics                                |       |
| Dimensions .....  | 31-11 |
| Leakage Distances .....                                 | 31-11 |
| Typical Mounting Configurations                         |       |
| and Hardware Diagrams .....                             | 31-12 |
| Tightening Torques for PDV/PVR Arrester Fasteners ..... | 31-12 |

**Warranty - Material**

Hubbell Power Systems, Inc. warrants all products sold by it to be merchantable (as such term is defined in the Uniform Commercial Code) and to be free from defects in material and workmanship. Buyer must notify the Company promptly of any claim under this warranty. The Buyer's exclusive remedy for breach of this warranty shall be the repair or replacement, F.O.B. factory, at the Company's option, of any product defective under the warranty which is returned to the Company within one year from the date of shipment. NO OTHER WARRANTY, WHETHER EXPRESS OR ARISING BY OPERATION OF LAW, COURSE OF DEALING, USAGE OF TRADE OR OTHERWISE IMPLIED, SHALL EXIST IN CONNECTION WITH THE COMPANY'S PRODUCTS OR ANY SALE OR USE THEREOF. The Company shall in no event be liable for any loss of profits or any consequential or special damages incurred by Buyer. The Company's warranty shall run only to the first Buyer of a product from the Company, from the Company's distributor, or from an original equipment manufacturer reselling the Company's product, and is non-assignable and non-transferable and shall be of no force and effect if asserted by any person other than such first Buyer. This warranty applies only to the use of the product as intended by Seller and does not cover any misapplication or misuse of said product.

**Warranty - Application**

Hubbell Power Systems, Inc. does not warrant the accuracy of and results from product or system performance recommendations resulting from any engineering analysis or study. This applies regardless of whether a charge is made for the recommendation, or if it is provided free of charge.

Responsibility for selection of the proper product or application rests solely with the purchaser. In the event of errors or inaccuracies determined to be caused by Hubbell Power Systems, Inc., its liability will be limited to the re-performance of any such analysis or study.

NOTE: Because Hubbell has a policy of continuous product improvement, we reserve the right to change design and specifications without notice.

©Copyright 2010 Hubbell Incorporated

## Introduction

The PDV100 arrester was introduced in 1986 as the very first U.S. non-ceramic arrester for heavy duty applications. Now, 22 years and 20 million arresters later, we are pleased to introduce the newest additions to the Ohio Brass arrester family and the Optima product line.

For distribution voltages, the new PDV65-Optima and PVR-Optima add all the benefits of polymer arresters, combined with a new disconnecter which improves system reliability and increases TOV capability. The PVR-Optima targets cable applications where low discharge voltages promote longer cable life. The PDV65-Optima is our normal duty arrester offering cost effective protection.

These new Optima arresters join an impressive list of advances that Ohio Brass has brought to arrester technology since it began making arresters in 1950. Improvements in design, such as the Optima have increased protective margins and durability. More important in terms of dollars and service reliability, Ohio Brass arresters have generated substantial savings for utilities. On the following pages are additional benefits and capabilities of our arresters.

## Benefits of the Optima

- Improved Isolator Disconnecter Reliability
- Isolator Design Good Down to One Amp Operation
- Saves Utilities Money and Improves System Reliability
- Higher 60 Hz TOV Capability
- Field Proven Sealing System

## Basic Construction

In Optima arresters, the Varistors are locked in place with tightly wound layers of fiberglass filament impregnated with epoxy resin. The arrester housing is made from our proprietary blend of ESP silicone alloy. In addition to ESP's exceptional performance as an insulator material, ESP's properties have been confirmed in a series of performance tests which include tracking resistance, contamination, aging, and seal design.

Optima arresters can be used with all standard mounting arms and brackets. They come with all the necessary fasteners, isolators, and terminal attachments. A specially designed glass-filled polyester insulating bracket, with integrated disconnecter, along with optional mounting brackets such as the cross arm or transformer bracket, enable mounting the arrester in a way which best suits each individual customer. Below is a typical cross section view of one of our distribution type arresters.

### Typical Cutaway (Arrester Only)

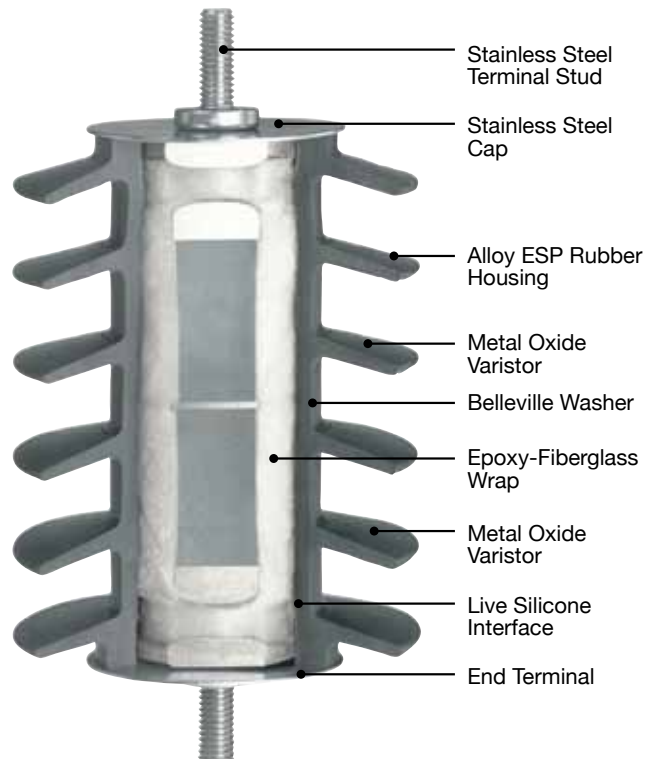

## Tests Verify PDV/PVR Arrester Design

### Full Scale Fault Current Tests

Short circuit design tests were performed on PDV65-Optima, PDV100-Optima, and PVR-Optima arresters in accordance with Section 8.18 of IEEE C62.11-2006 Standard. Eight arresters of each type were tested. Per the standard, four arresters were tested at the claimed high current withstand capability. Two of these samples were assembled with internal fuse wires. The other two were good arresters which were subjected to an overvoltage condition, which failed the arrester (with a weak source). The arrester was immediately subjected to the claimed high current fault current. Two additional arresters were subjected to fault currents approximately half of the claimed high current value. The fault current duration for all high current tests was 12 cycles. Finally, two arresters were subjected to a nominal 600 amp, 1 second fault current test. All test arresters were 17 kV MCOV, the longest single module configuration used for each arrester type. Tests were performed at full voltage (17 kV rms).

Successful performance was demonstrated when the epoxy-fiberglass wrapped arrester modules burned through to relieve internal pressures associated with the fault current arcing. In all cases, the arrester remained intact, except at the high current levels which caused polymer housing fragmentation, which is acceptable.

The following table summarizes the claimed short circuit capabilities for the arresters.

| Arrester Type | Short Circuit Test Current $A_{(rms)}$ | Short Circuit Test Duration-Sec. |
|---------------|--|----------------------------------|
| PDV65-Optima  | 15,000                                 | .20                              |
| PDV65-Optima  | 7,500                                  | .20                              |
| PDV65-Optima  | 500                                    | 1.0                              |
| PDV100-Optima | 20,000                                 | .20                              |
| PDV100-Optima | 10,000                                 | .20                              |
| PDV100-Optima | 600                                    | 1.0                              |
| PVR-Optima    | 20,000                                 | .20                              |
| PVR-Optima    | 10,000                                 | .20                              |
| PVR-Optima    | 500                                    | 1.0                              |

### PDV/PVR Design Test Report Summary

The PDV100-Optima and PDV65-Optima arresters have been tested in accordance with IEEE Standard C62.11-2006 for metal-oxide surge arresters. There is no standard for PVR arresters so they were tested per the heavy duty requirement.

The PDV100-Optima/PVR-Optima meet or exceed all the requirements for heavy-duty distribution arrester designs. The PDV65-Optima meets or exceeds all requirements for normal duty surge arresters.

The table below summarizes the capabilities of these designs.

| Test                        | PDV100-Optima & PVR-Optima            | PDV65-Optima                         |
|-----------------------------|---------------------------------------|--------------------------------------|
| High Current-Short Duration | 2 - 100 kA Discharges                 | 2 - 65 kA Discharges                 |
| Low Current Long Duration   | 20 - 250A x 2000 $\mu$ sec Discharges | 20 - 75A x 2000 $\mu$ sec Discharges |
| Duty Cycle                  | 20 - 10 kA plus 2 - 40 kA Discharges  | 22 - 5 kA Discharges                 |

*The above is merely a summary of a portion of the design tests performed on PDV/PVR arresters. Contact your Ohio Brass sales representative for complete test reports on these two arresters.*

## Optima Design Improvements

The Optima incorporates a redesigned disconnecter and a new line end protective cap. Both of these are aimed at improving the overall system reliability.

### Improved Disconnecter Reliability

Historically distribution class surge arresters were installed with a ground lead disconnecting device. The purpose of this component is to allow a failed (shorted) arrester to automatically disconnect from the line. This allowed the line to quickly be returned to service and also provided a visual indication to crews as to which arrester had failed and needed to be replaced.

Occasionally under conditions that allowed a low fault current to flow through the arrester - damage will occur to the disconnecter's internal grading resistor. When this condition occurs the disconnecter will not operate. With the introduction of polymer arrester designs this situation was aggravated since it was nearly impossible to identify a failed arrester from the ground and the circuit would be locked out. The Optima design incorporates a capacitor-graded Optima disconnecter into the insulated bracket attached to the base end of the arrester.

The following curve shows that the low current end of the detonation range for the capacitor-graded Optima disconnecter has been extended from 20 amps down to 1 amp. This assures proper disconnecter operation even at very low fault current levels.

Optima Disconnecter Detonation Curve

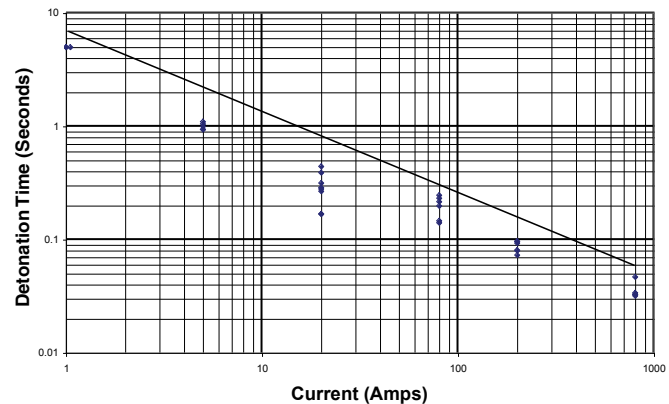

Laboratory testing has confirmed that the electrical integrity of the capacitor-graded Optima disconnecter is not affected by exposure to prolonged TOV conditions or 100 kA lightning duty. In the unlikely event of arrester failure, it does ensure proper detonation of the disconnecter, separating the arrester ground lead and preventing lockout from occurring.

### Universal Protective Cap for PDV100 & PDV65 Optima

The new Optima line end protective cap is designed for single or thru connection lead wires. Each side of the cap has webbed fingers which prevent accidental contact with the arrester top end hardware by wildlife.

## Selection Considerations

| NORMALLY RECOMMENDED PDV/PVR<br>MCOV FOR VARIOUS SYSTEM VOLTAGES |         |   |   |
|--|---------|---|---|
| System L-L Voltage<br>kV   |         | Arrester MCOV-kV                                  |   |
| Nominal  | Maximum | Effectively<br>Grounded (Wye)<br>Neutral Circuits | Impedance<br>Grounded,<br>Ungrounded, or<br>Delta<br>Circuits |
| 2.4  | 2.54    | —   | 2.55  |
| 4.16   | 4.4     | 2.55  | 5.1   |
| 4.8  | 5.08    | —   | 5.1   |
| 6.9  | 7.26    | —   | 7.65  |
| 12.0   | 12.7    | 7.65  | 12.7  |
| 12.47  | 13.2    | 7.65  | —   |
| 13.2   | 13.97   | 8.4   | —   |
| 13.8   | 14.52   | 8.4   | 15.3  |
| 20.78  | 22.0    | 12.7  | 22.0  |
| 22.86  | 24.2    | 15.3  | 22.0  |
| 23.0   | 24.34   | —   | 22.0  |
| 24.94  | 26.4    | 15.3  | —   |
| 34.5   | 36.5    | 22.0  | 29.0  |

Selection of arrester size is based upon the maximum continuous operating voltage (MCOV) that is applied across the arrester in service (line-to-ground). For arresters on effectively grounded systems, this is normally the maximum line-to-ground voltage — e.g., 7.65 kV on a 12.47 kV multi-grounded system. For ungrounded or impedance-grounded systems, the MCOV should be at least 90 percent of maximum phase-to-phase voltage. Smaller arresters than shown may be used, contact your Ohio Brass representative for details.

For convenience, the data shown in this catalog includes the traditional duty-cycle voltage rating associated with the MCOV of each arrester.

The selection of the actual type will be primarily governed by the insulation being protected.

## Temporary Overvoltage

MOV arresters by nature are voltage sensitive devices. At normal line to ground voltages, the arrester is energized at its MCOV (Maximum Continuous Operating Voltage) and conducts very little current. During disturbances on the system, the arrester can see elevated voltages and therefore higher 60Hz current through the unit. The magnitude and duration of the system-generated temporary over voltage (TOV) that the arrester can withstand is best expressed graphically. The two curves on the next page shows the TOV capability versus time for OB distribution style arresters. The

Optima demonstrates an improved TOV capability. The capacitance-based isolator in Optima improves the TOV capability while increasing the reliability of disconnecter function. The Optima technology results in a family of TOV curves that are a function of voltage rating of the arrester. Curves for other ratings can be found in our design test report online at <http://www.hubbellpowersystems.com>. Contact your HPS representative for more information on this new technology.

ANSI No Prior Duty TOV Curves, Distribution Arresters Without Optima Bracket

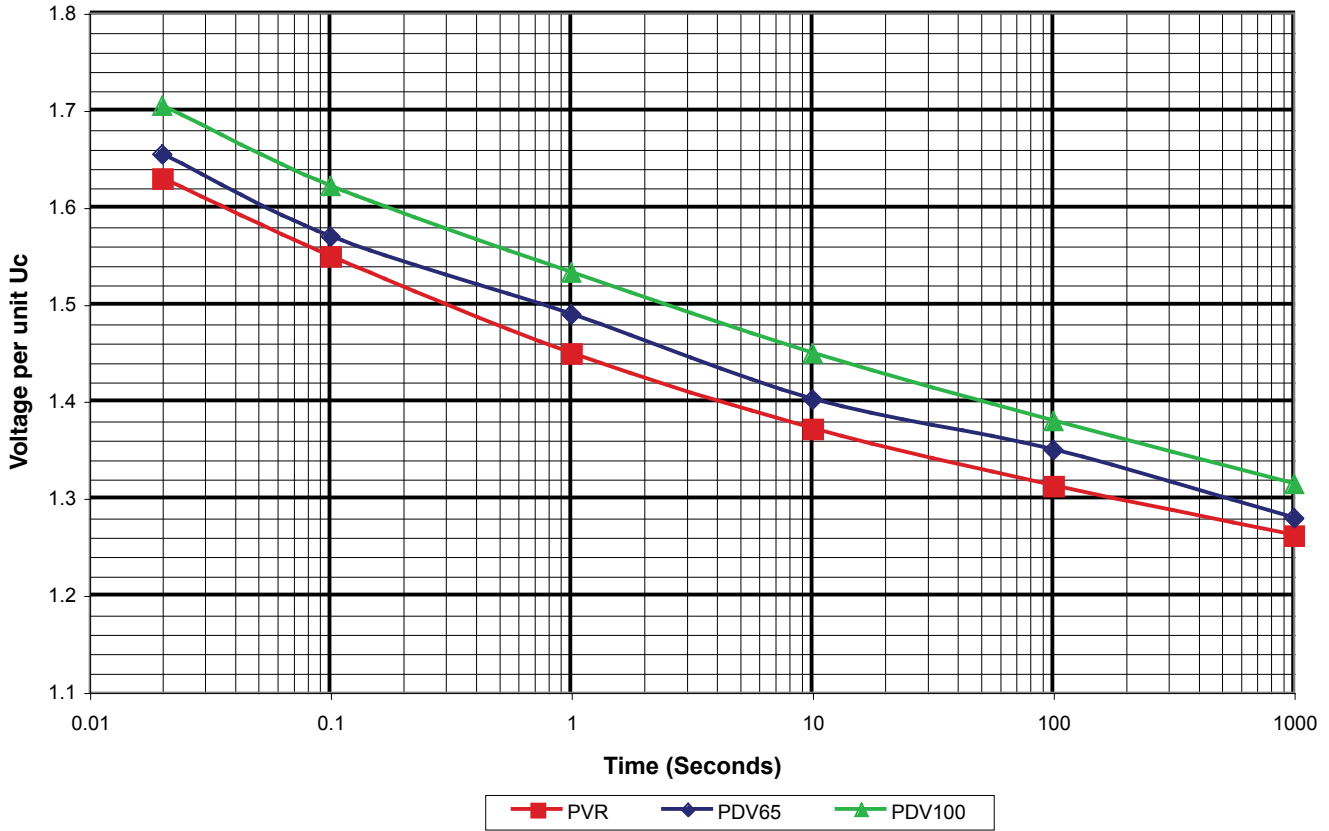

ANSI No Prior Duty TOV Curves for PDV100-Optima Arresters

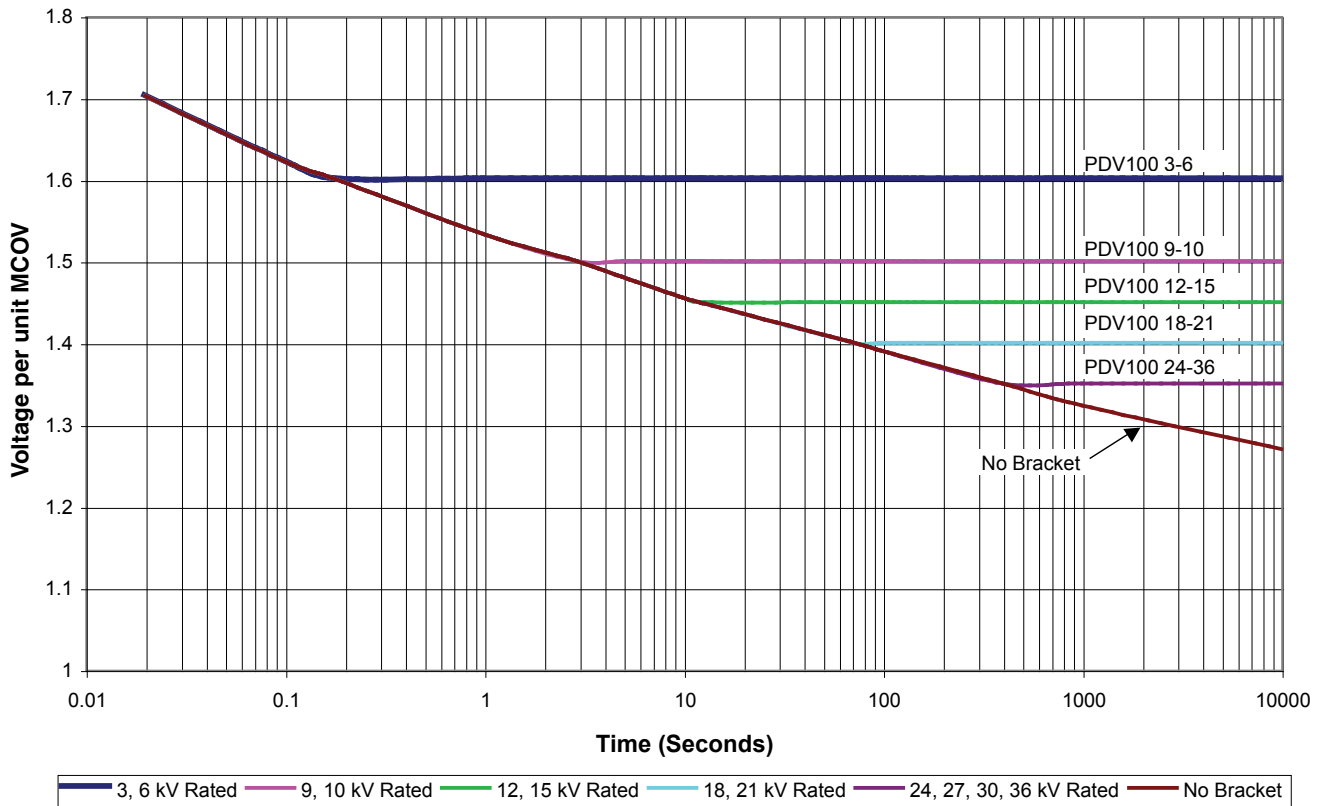

**ANSI No Prior Duty TOV Curves for PDV65-Optima Arresters**

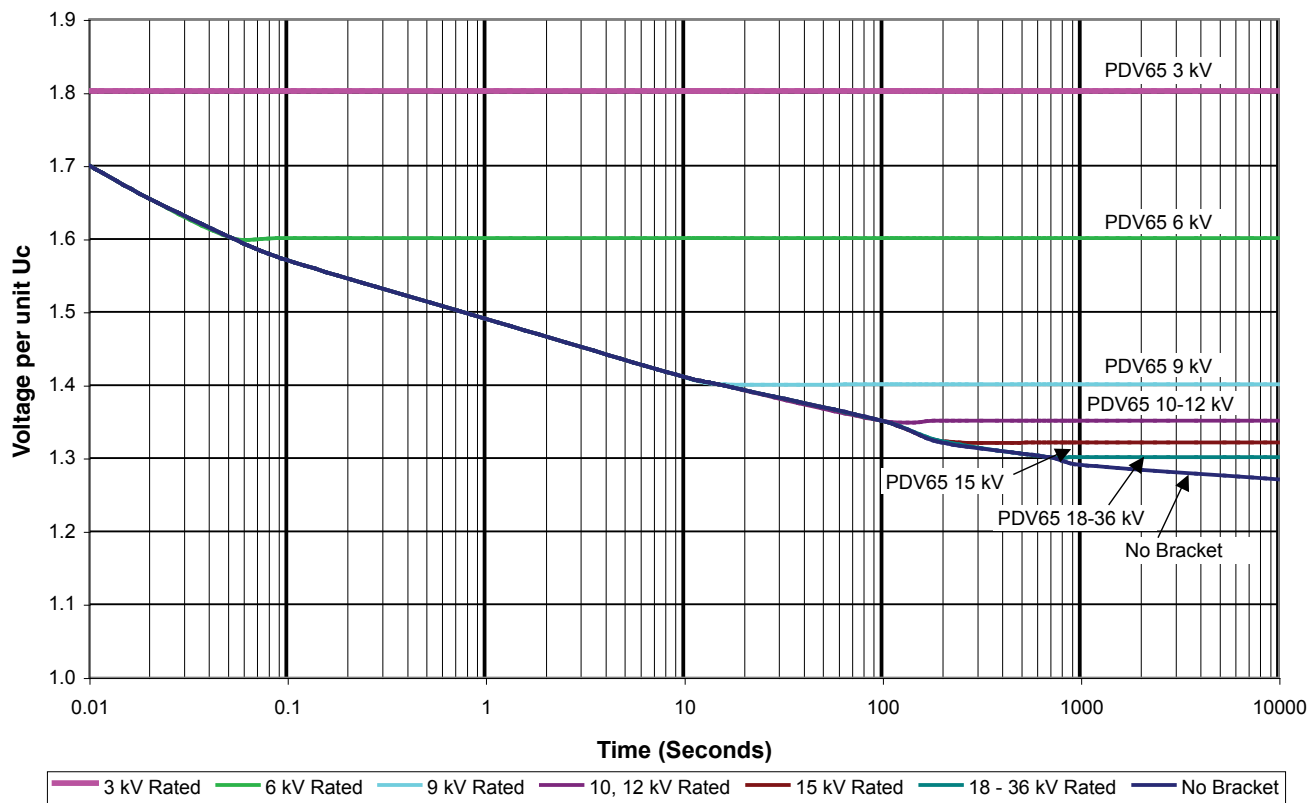

**ANSI No Prior Duty TOV Curves for PVR-Optima Arresters**

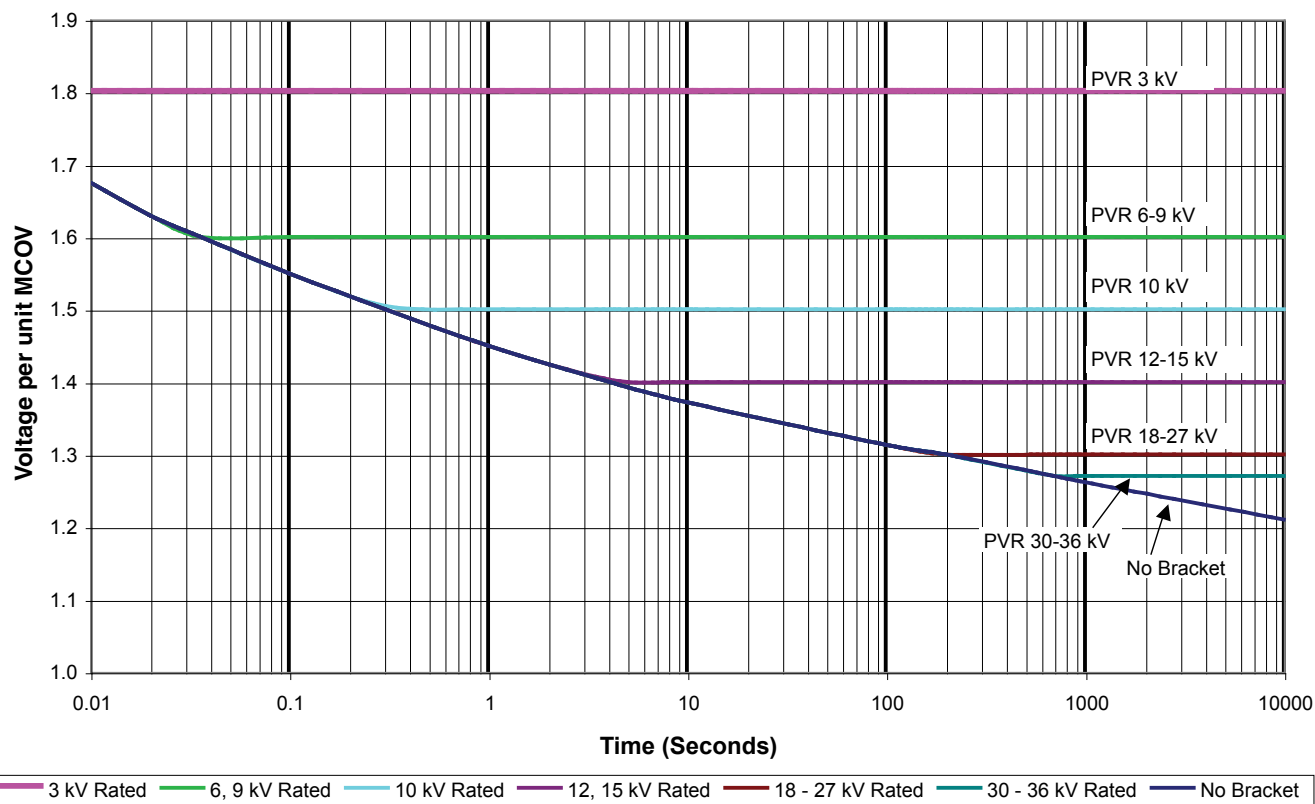

## How to Specify a 7XXX Suffix Hardware Code

### Procedure

(Example) To obtain the 7000 code suffix number for a 10 kV duty cycle rated PDV65-Optima arrester equipped with a line terminal, wire clamp, insulating base bracket, NEMA crossarm hanger for a 4 x 5 crossarm and a ground lead isolator with terminal nut, follow this procedure:

**Step 1** - The catalog number of the basic 10 kV PDV65-Optima arrester is 217259.

**Step 2** - The 72XX code in the table below specifies the top terminal and wire clamp.

**Step 3** - The 7X2X code specifies the insulating base bracket and 4 x 5 NEMA crossarm hanger.

**Step 4** - The 7XX4 code specifies the ground lead isolator, terminal nut and nut.

**Step 5** - Combine the three suffix digits following the 7 in their correct order gives us the suffix code: 7224.

**Step 6** - Order the arrester by complete catalog number 2172597224.

### For all PDV100 & PDV65 Optima Arresters:

The 73XX code will be the only one with a cap. The 74XX code is not available since the Optima only has one cap style which is the newest design.

For all PVR Optima Arresters Cap 73XX and 74XX are available.

### Notes:

1. The ground isolator identified in codes 7003, 7004 and 7005 is an integral part of the insulating base bracket. The color for the insulating base bracket/ground lead isolator assembly is ANSI-70 gray.

2. Code 7030 identifies the insulating base bracket/transformer mounting bracket combination. The transformer mounting bracket used in code 7030 is Ohio Brass part number 2730664004 ( $\leq 8.4$  kV MCOV) and 2730254004 ( $\geq 10.2$  kV MCOV). A drawing of the 273066 bracket is included on page 12 to assist in applying this arrester. Contact your HPS representative for further information.

3. All terminals are solderless, clamp type, suitable for conductor sizes from No. 6 AWG solid to No. 2 AWG stranded. If the spacing of the mounting holes on mounting brackets listed are not suitable for the intended application, other mounting brackets are available and in these cases, the HPS sales representative should be consulted.

**TABLE A TOP TERMINAL HARDWARE**

|  |                                  |                             |  |  |   |   |  |
|--|----------------------------------|-----------------------------|--|--|---|---|--|
|  | 71XX<br>3/8" Stud<br>(No Option) | 72XX<br>Nut & Wire<br>Clamp | 73XX<br>Nut, Wire<br>Clamp &<br>Protective Cap<br>(One Slot)<br>(Optima) | 74XX<br>Nut, Wire<br>Clamp &<br>Protective Cap<br>(One Hole)<br>(PVR only) | 75XX<br>Nut, Wire<br>Clamp,<br>Protective Cap<br>(One Slot), &<br>18" Wire Lead | 76XX<br>Flipper Fuse<br>Assembly<br>Nut & Wire<br>Clamp | 77XX<br>Nut, Wire<br>Clamp,<br>3-Piece<br>Protective Cap |
|--|----------------------------------|-----------------------------|--|--|---|---|--|

**TABLE B MOUNTING HARDWARE**

|                                   |  |   |  |   |   |   |  |
|-----------------------------------|--|---|--|---|---|---|--|
| 7X0X<br>No Bracket<br>No Isolator | 7X1X<br>Insulated<br>Base Bracket<br>with Isolator | 7X2X<br>Insulated<br>Base Bracket<br>with Isolator<br>& NEMA 4x5<br>X-Arm Bracket | 7X3X<br>Insulated<br>Base Bracket<br>with Isolator<br>and Transformer<br>Bracket | 7X4X<br>Insulated<br>Base Bracket<br>with Isolator<br>and NEMA<br>Angle Bracket | 7X5X<br>Insulated<br>Base Bracket<br>with Isolator<br>& NEMA 6x6<br>X-Arm Bracket | 7X6X<br>Metal Base<br>Mounting<br>Strap | 7X7X<br>Metal Base<br>Mounting<br>Strap and<br>NEMA 4x5<br>X-Arm Bracket |
|-----------------------------------|--|---|--|---|---|---|--|

**TABLE C LOWER TERMINAL HARDWARE**

|  |                                   |   |  |  |  |  |   |
|--|-----------------------------------|---|--|--|--|--|---|
|  | 7XX1*<br>3/8" Stud<br>(No Option) | 7XX2*<br>Nut, Washers<br>& Threaded<br>Terminal Nut | 7XX3<br>Isolator, Nut,<br>Ground Strap<br>Washer | 7XX4<br>Isolator, Nut,<br>Washer &<br>Threaded<br>Terminal Nut | 7XX5<br>Isolator, Nut,<br>Protective Cap<br>(2 Slot), Washer<br>& Threaded<br>Terminal Nut | 7XX6*<br>Ground Strap,<br>Nut, Washers<br>& Threaded<br>Terminal Nut | 7XX7*<br>Nut, Washers<br>& Threaded<br>Terminal Nut |
|--|-----------------------------------|---|--|--|--|--|---|

\* Must be ordered in conjunction with codes 7000, 7060 or 7070.

## Insulation Coordination

These electrical characteristics are used to determine protective margins for insulation levels in use.

These two figures illustrate a 34.5 kV effectively grounded system, 150 kV BIL, protected with 22 kV MCOV Type PDV arresters.

Figure 1 shows equipment protected with a PDV100-Optima arrester Catalog Number 213722 and Figure 2 shows the same equipment protected with a PDV65-Optima arrester Catalog Number 213272.

The protective margins are calculated using the following formula:

$$\left( \frac{\text{Insulation Level}}{\text{Arrester Discharge Voltage}} - 1 \right) \times 100 = \% \text{ Margin}$$

The insulation levels are obtained from the manufacturer of the equipment being protected. The arrester discharge voltages are obtained from the table on page 8. For example, the protective margin for the BIL is determined by first finding the arrester discharge voltage at the impulse current level selected. In this example, the 10 kA discharge current is used as representative of typical lightning stroke currents discharged through the arrester. The 10 kA 8/20 discharge voltage of catalog number 213722 is 85.5 kV. The percent protective margin using the formula is:

$$\left( \frac{150 \text{ kV}}{85.5 \text{ kV}} - 1 \right) \times 100 = 75 \text{ percent.}$$

The protective margins for other impulse currents are found in a similar fashion. In the case of the PDV65-Optima arrester, the 10 kA 8/20 discharge voltage of the arrester is 97.2 kV. This results in a protective margin of 54 percent.

These examples include many simplifying assumptions. Not included are the effects of faster rates of current rise on the discharge voltage, reduced insulation levels due to various factors, and line and ground leads.

For example, if the effect of lead length was included in the calculations and 1.6 kV per foot of lead length added to the discharge voltage of the arrester. With two feet of line lead and two feet of ground lead, 6.4 kV is added to the published discharge voltage of the arrester. Therefore, the discharge voltage of the PDV100-Optima is effectively 91.9 kV, resulting in a reduction of protective margin to 63 percent at 10 kA. In the case of the PDV65-Optima arrester, the 97.2 kV discharge voltage of the arrester is added to the 6.4 kV from the leads resulting in equipment seeing 103.6 kV reducing the protective margin to 44.7 percent.

The chopped wave strength of the insulation being protected is typically coordinated with the .5 μsec discharge voltage of the surge arrester. The heavy duty PDV100-Optima uses a 10 kA current while the PDV65-Optima catalog value is for a 5 kA peak current.

The switching surge insulation level of the equipment is coordinated with the 500 ampere switching discharge voltage of the surge arrester.

The effects of faster rates of rise and of reduced insulation strength due to aging effects would result in further reduced protective margins.

Industry standards recommend minimum margins of 20 percent for the chopped wave and BIL levels and 15 percent for switching surge protection.

**Fig. 1**

### PDV100-Optima METAL-OXIDE ARRESTER INSULATION COORDINATION 34.5 kV System

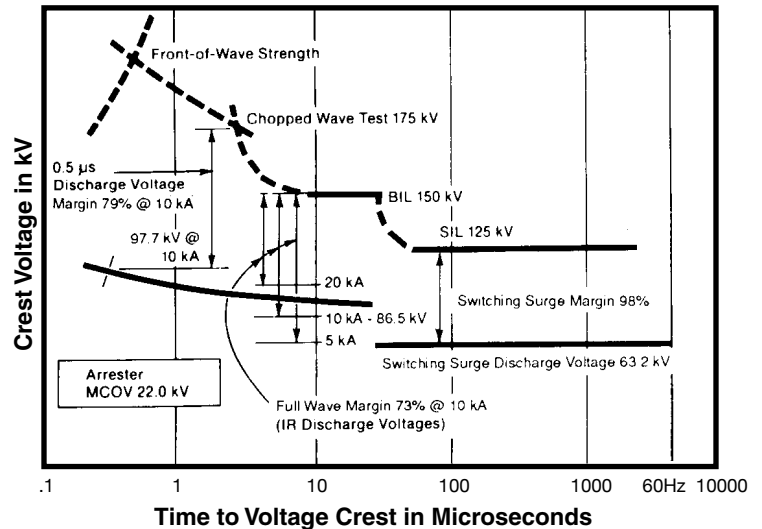

**Fig. 2**

### PDV65-Optima METAL-OXIDE ARRESTER INSULATION COORDINATION 34.5 kV System

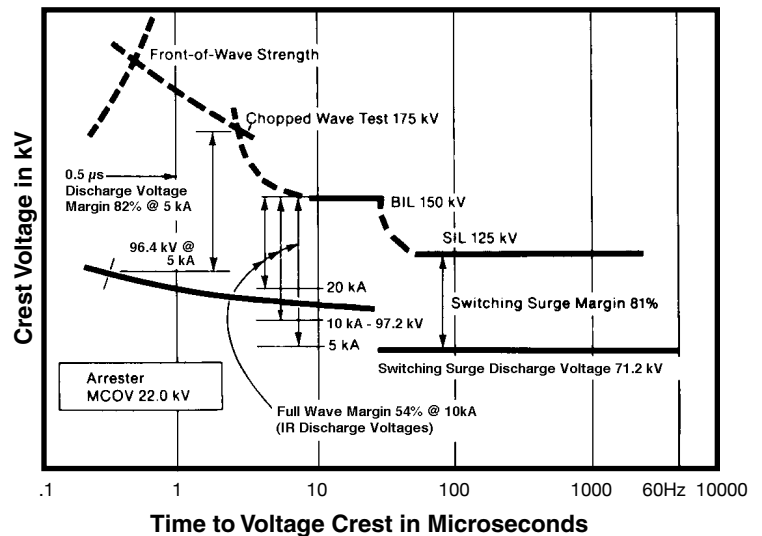

## Electrical Characteristics

### Heavy Duty PDV100-Optima

| Rated Voltage<br>kV | MCOV<br>kV | Unit<br>Catalog<br>Number | 0.5 $\mu$ sec<br>10kA<br>Maximum<br>IR-kV <sup>(1)</sup> | 500 A<br>Switching Surge<br>Maximum IR-<br>kV <sup>(2)</sup> | 8/20 Maximum Discharge Voltage - kV |      |       |       |       |       |
|---------------------|------------|---------------------------|--|--|-------------------------------------|------|-------|-------|-------|-------|
|                     |            |                           |  |  | 1.5 kA                              | 3 kA | 5 kA  | 10 kA | 20 kA | 40 kA |
| 3                   | 2.55       | 213703                    | 10.6   | 7.6  | 8.0                                 | 8.5  | 9.0   | 9.9   | 11.1  | 13.2  |
| 6                   | 5.1        | 213705                    | 21.3   | 15.3   | 15.9                                | 17.0 | 18.0  | 19.8  | 22.3  | 26.5  |
| 9                   | 7.65       | 213708                    | 31.2   | 22.4   | 23.3                                | 24.9 | 26.4  | 29.0  | 32.6  | 38.8  |
| 10                  | 8.4        | 213709                    | 34.0   | 24.4   | 25.4                                | 27.1 | 28.8  | 31.6  | 35.6  | 42.3  |
| 12                  | 10.2       | 213710                    | 40.4   | 29.0   | 30.3                                | 32.3 | 34.2  | 37.6  | 42.3  | 50.3  |
| 15                  | 12.7       | 213713                    | 51.4   | 36.9   | 38.5                                | 41.1 | 43.5  | 47.8  | 53.8  | 64.0  |
| 18                  | 15.3       | 213715                    | 60.6   | 43.5   | 45.4                                | 48.4 | 51.3  | 56.4  | 63.5  | 75.5  |
| 21                  | 17.0       | 213717                    | 68.3   | 49.0   | 51.1                                | 54.5 | 57.8  | 63.5  | 71.4  | 85.0  |
| 24                  | 19.5       | 213720                    | 81.9   | 58.8   | 61.3                                | 65.5 | 69.3  | 76.2  | 85.7  | 102.0 |
| 27                  | 22.0       | 213722                    | 91.9   | 65.9   | 68.8                                | 73.4 | 77.8  | 85.5  | 96.2  | 114.4 |
| 30                  | 24.4       | 213724                    | 101.1  | 72.5   | 75.7                                | 80.7 | 85.5  | 94.0  | 105.8 | 125.8 |
| 36                  | 29.0       | 213729                    | 121.4  | 87.0   | 97.9                                | 97.0 | 102.7 | 112.9 | 127.0 | 151.1 |

### Normal Duty PDV65-Optima

| Rated Voltage<br>kV | MCOV<br>kV | Unit<br>Catalog<br>Number | 0.5 $\mu$ sec<br>10kA<br>Maximum<br>IR-kV <sup>(1)</sup> | 500 A<br>Switching Surge<br>Maximum IR-<br>kV <sup>(2)</sup> | 8/20 Maximum Discharge Voltage - kV |       |       |       |       |       |
|---------------------|------------|---------------------------|--|--|-------------------------------------|-------|-------|-------|-------|-------|
|                     |            |                           |  |  | 1.5 kA                              | 3 kA  | 5 kA  | 10 kA | 20 kA | 40 kA |
| 3                   | 2.55       | 217253                    | 12.5   | 8.5  | 9.8                                 | 10.3  | 11.0  | 12.3  | 14.3  | 18.5  |
| 6                   | 5.1        | 217255                    | 25.0   | 17.0   | 19.5                                | 20.5  | 22.0  | 24.5  | 28.5  | 37.0  |
| 9                   | 7.65       | 217258                    | 33.5   | 23.5   | 26.0                                | 28.0  | 30.0  | 33.0  | 39.0  | 50.5  |
| 10                  | 8.4        | 217259                    | 36.0   | 25.4   | 27.0                                | 29.5  | 31.5  | 36.0  | 41.5  | 53.0  |
| 12                  | 10.2       | 217560                    | 42.4   | 31.3   | 33.8                                | 36.3  | 38.5  | 42.8  | 49.0  | 60.9  |
| 15                  | 12.7       | 213263                    | 54.0   | 39.9   | 43.1                                | 46.3  | 49.0  | 54.4  | 62.4  | 78.0  |
| 18                  | 15.3       | 213265                    | 62.8   | 46.4   | 50.1                                | 53.8  | 57.0  | 63.3  | 72.6  | 91.2  |
| 21                  | 17.0       | 213267                    | 68.3   | 50.5   | 54.5                                | 58.5  | 62.0  | 68.9  | 79.0  | 98.3  |
| 24                  | 19.5       | 217570                    | 84.8   | 62.6   | 67.6                                | 72.6  | 77.0  | 85.6  | 98.0  | 121.9 |
| 27                  | 22.0       | 213272                    | 96.4   | 71.2   | 76.9                                | 82.6  | 87.5  | 97.2  | 111.4 | 139.0 |
| 30                  | 24.4       | 213274                    | 104.3  | 74.5   | 81.5                                | 88.0  | 93.5  | 104.9 | 120.5 | 149.1 |
| 36                  | 29.0       | 213279                    | 125.6  | 92.8   | 100.2                               | 107.6 | 114.0 | 126.7 | 145.2 | 176.7 |

### Riser-Pole PVR-Optima

| Rated Voltage<br>kV | MCOV<br>kV | Unit<br>Catalog<br>Number | 0.5 $\mu$ sec<br>10kA<br>Maximum<br>IR-kV <sup>(1)</sup> | 500 A<br>Switching Surge<br>Maximum IR-<br>kV <sup>(2)</sup> | 8/20 Maximum Discharge Voltage - kV |      |      |       |       |       |
|---------------------|------------|---------------------------|--|--|-------------------------------------|------|------|-------|-------|-------|
|                     |            |                           |  |  | 1.5 kA                              | 3 kA | 5 kA | 10 kA | 20 kA | 40 kA |
| 3                   | 2.55       | 221603                    | 9.9  | 6.6  | 7.2                                 | 7.8  | 8.2  | 9.1   | 10.4  | 12.3  |
| 6                   | 5.1        | 221605                    | 20.0   | 13.3   | 14.6                                | 15.7 | 16.6 | 18.3  | 21.0  | 24.8  |
| 9                   | 7.65       | 221608                    | 26.8   | 17.8   | 19.5                                | 21.0 | 22.2 | 24.5  | 28.1  | 33.2  |
| 10                  | 8.4        | 221609                    | 29.5   | 19.6   | 21.5                                | 23.1 | 24.4 | 27.0  | 31.0  | 36.6  |
| 12                  | 10.2       | 221610                    | 35.5   | 23.6   | 25.9                                | 27.9 | 29.4 | 32.5  | 37.3  | 44.0  |
| 15                  | 12.7       | 221613                    | 44.2   | 29.4   | 32.2                                | 34.7 | 36.7 | 40.5  | 46.5  | 54.8  |
| 18                  | 15.3       | 221615                    | 53.4   | 35.5   | 38.9                                | 41.9 | 44.3 | 48.9  | 56.1  | 66.2  |
| 21                  | 17.0       | 221617                    | 60.7   | 40.3   | 44.3                                | 47.6 | 50.3 | 55.6  | 63.8  | 75.3  |
| 24                  | 19.5       | 221620                    | 70.9   | 47.1   | 51.7                                | 55.6 | 58.7 | 64.9  | 74.4  | 87.9  |
| 27                  | 22.0       | 221622                    | 78.6   | 52.2   | 57.3                                | 61.7 | 65.2 | 72.0  | 82.6  | 97.5  |
| 30                  | 24.4       | 221624                    | 88.5   | 58.7   | 64.5                                | 69.4 | 73.3 | 81.0  | 92.9  | 110.0 |
| 36                  | 29.0       | 221629                    | 105.0  | 69.7   | 76.5                                | 82.4 | 87.0 | 96.1  | 110.0 | 130.0 |

All Ohio Brass Arresters are fully compliant with ANSI/IEEE C62.11 Standard

- (1) Maximum discharge voltage for a 10-kA impulse current wave which produces a voltage wave cresting in 0.5  $\mu$ s. This can be used for coordination where front-of-wave sparkover was formerly used.
- (2) Based on a 500A surge of 45- $\mu$ s time to crest.

**Physical Characteristics**
**Heavy Duty  
PDV100-Optima**

| Rated Voltage | MCOV | Unit Catalog Number | Height with Insulating Base Bracket | Leakage Distance Terminal to Base | Mounting Clearance <sup>(1)</sup> |                       | Approx. Net Weights |                                   |  |
|---------------|------|---------------------|-------------------------------------|-----------------------------------|-----------------------------------|-----------------------|---------------------|-----------------------------------|--|
|               |      |                     |                                     |                                   | Center Line to Center Line        | Center Line to Ground | Unit Only           | Unit with Insulating Base Bracket | Unit with Insulating Base Bracket and NEMA Bracket |
|               |      |                     |                                     |                                   | inches                            | inches                | pounds              | pounds                            | pounds   |
| 3             | 2.55 | 213703              | 6.8                                 | 8.5                               | 5                                 | 3                     | 1.9                 | 2.9                               | 5.4  |
| 6             | 5.1  | 213705              | 7.6                                 | 11.3                              | 5.4                               | 3.4                   | 2.3                 | 3.3                               | 5.8  |
| 9             | 7.65 | 213708              | 8.7                                 | 14.4                              | 6                                 | 4                     | 2.8                 | 3.8                               | 6.3  |
| 10            | 8.4  | 213709              | 8.7                                 | 14.4                              | 6.2                               | 4.2                   | 2.8                 | 3.8                               | 6.3  |
| 12            | 10.2 | 213710              | 9.3                                 | 17.0                              | 7.5                               | 5.5                   | 3.3                 | 4.3                               | 6.8  |
| 15            | 12.7 | 213713              | 11.6                                | 25.2                              | 8.5                               | 6.5                   | 4.6                 | 5.6                               | 8.1  |
| 18            | 15.3 | 213715              | 11.6                                | 25.2                              | 9.5                               | 7.5                   | 4.6                 | 5.6                               | 8.1  |
| 21            | 17.0 | 213717              | 12.4                                | 28.1                              | 10.0                              | 8.0                   | 5.2                 | 6.2                               | 8.7  |
| 24            | 19.5 | 213720              | 14.8                                | 36.5                              | 12.0                              | 10.0                  | 7.0                 | 8.3                               | 10.8   |
| 27            | 22.0 | 213722              | 16.4                                | 39.6                              | 13.0                              | 11.0                  | 7.4                 | 8.7                               | 11.3   |
| 30            | 24.4 | 213724              | 16.9                                | 42.2                              | 14.0                              | 12.0                  | 7.9                 | 9.2                               | 11.7   |
| 36            | 29.0 | 213729              | 19.3                                | 50.4                              | 16.5                              | 14.5                  | 9.0                 | 10.3                              | 12.8   |

**Normal Duty  
PDV65-Optima**

| Rated Voltage | MCOV | Unit Catalog Number | Height with Insulating Base Bracket | Leakage Distance Terminal to Base | Mounting Clearance <sup>(1)</sup> |                       | Approx. Net Weights |                                   |  |
|---------------|------|---------------------|-------------------------------------|-----------------------------------|-----------------------------------|-----------------------|---------------------|-----------------------------------|--|
|               |      |                     |                                     |                                   | Center Line to Center Line        | Center Line to Ground | Unit Only           | Unit with Insulating Base Bracket | Unit with Insulating Base Bracket and NEMA Bracket |
|               |      |                     |                                     |                                   | inches                            | inches                | pounds              | pounds                            | pounds   |
| 3             | 2.55 | 217253              | 9.3                                 | 15.4                              | 4.8                               | 3                     | 2.6                 | 3.5                               | 6.0  |
| 6             | 5.1  | 217255              | 9.3                                 | 15.4                              | 5                                 | 3.2                   | 2.6                 | 3.5                               | 6.0  |
| 9             | 7.65 | 217258              | 9.3                                 | 15.4                              | 5.6                               | 3.8                   | 2.6                 | 3.5                               | 6.0  |
| 10            | 8.4  | 217259              | 9.3                                 | 15.4                              | 5.8                               | 4.1                   | 2.6                 | 3.5                               | 6.0  |
| 12            | 10.2 | 217560              | 9.3                                 | 15.4                              | 7.5                               | 5.7                   | 2.6                 | 3.5                               | 6.0  |
| 15            | 12.7 | 213263              | 12.3                                | 25.5                              | 8.5                               | 6.7                   | 4.2                 | 5.2                               | 7.1  |
| 18            | 15.3 | 213265              | 12.3                                | 25.5                              | 9.5                               | 7.7                   | 4.2                 | 5.2                               | 7.1  |
| 21            | 17.0 | 213267              | 12.3                                | 25.5                              | 10                                | 8.2                   | 4.2                 | 5.2                               | 7.1  |
| 24            | 19.5 | 217570              | 14.7                                | 30.8                              | 12                                | 10.2                  | 6.7                 | 7.7                               | 10.7   |
| 27            | 22.0 | 213272              | 17.7                                | 40.9                              | 13                                | 11.2                  | 6.7                 | 7.7                               | 10.7   |
| 30            | 24.4 | 213274              | 17.7                                | 40.9                              | 13.6                              | 11.8                  | 6.7                 | 7.7                               | 10.7   |
| 36            | 29.0 | 213279              | 20.7                                | 51.0                              | 16.2                              | 14.4                  | 8.2                 | 9.2                               | 11.2   |

**Riser Pole  
PVR-Optima**

| Rated Voltage | MCOV | Unit Catalog Number | Height with Insulating Base Bracket | Leakage Distance Terminal to Base | Mounting Clearance <sup>(1)</sup> |                       | Approx. Net Weights |                                   |  |
|---------------|------|---------------------|-------------------------------------|-----------------------------------|-----------------------------------|-----------------------|---------------------|-----------------------------------|--|
|               |      |                     |                                     |                                   | Center Line to Center Line        | Center Line to Ground | Unit Only           | Unit with Insulating Base Bracket | Unit with Insulating Base Bracket and NEMA Bracket |
|               |      |                     |                                     |                                   | inches                            | inches                | pounds              | pounds                            | pounds   |
| 3             | 2.55 | 221603              | 7.0                                 | 8.0                               | 5.0                               | 3.0                   | 2.3                 | 3.3                               | 5.8  |
| 6             | 5.1  | 221605              | 9.4                                 | 15.4                              | 5.3                               | 3.3                   | 3.1                 | 4.1                               | 6.6  |
| 9             | 7.65 | 221608              | 9.4                                 | 15.4                              | 5.8                               | 3.8                   | 3.1                 | 4.1                               | 6.6  |
| 10            | 8.4  | 221609              | 9.4                                 | 15.4                              | 6.0                               | 4.0                   | 3.1                 | 4.1                               | 6.6  |
| 12            | 10.2 | 221610              | 9.4                                 | 15.4                              | 7.3                               | 5.3                   | 3.3                 | 4.3                               | 6.8  |
| 15            | 12.7 | 221613              | 12.4                                | 26.0                              | 8.3                               | 6.3                   | 4.5                 | 5.5                               | 8.0  |
| 18            | 15.3 | 221615              | 12.4                                | 26.0                              | 9.2                               | 7.2                   | 5.1                 | 6.1                               | 8.6  |
| 21            | 17.0 | 221617              | 12.4                                | 26.0                              | 9.7                               | 7.7                   | 5.1                 | 6.1                               | 8.6  |
| 24            | 19.5 | 221620              | 14.7                                | 30.8                              | 11.6                              | 9.6                   | 6.1                 | 7.4                               | 9.9  |
| 27            | 22.0 | 221622              | 21.1                                | 52.0                              | 12.5                              | 10.5                  | 8.3                 | 9.6                               | 12.1   |
| 30            | 24.4 | 221624              | 21.1                                | 52.0                              | 13.5                              | 11.5                  | 8.3                 | 9.6                               | 12.1   |
| 36            | 29.0 | 221629              | 21.1                                | 52.0                              | 16.0                              | 14.0                  | 9.5                 | 10.8                              | 13.3   |

(1) Center line to center line is equivalent to phase-to-phase; center line to ground is equivalent to phase-to-ground. These are recommended minimum clearances only and as such are not intended to take precedence over existing construction codes or specifications.

For appropriate packed weight, add 0.5 lb. per arrester.

## Typical Mounting Configurations and Hardware

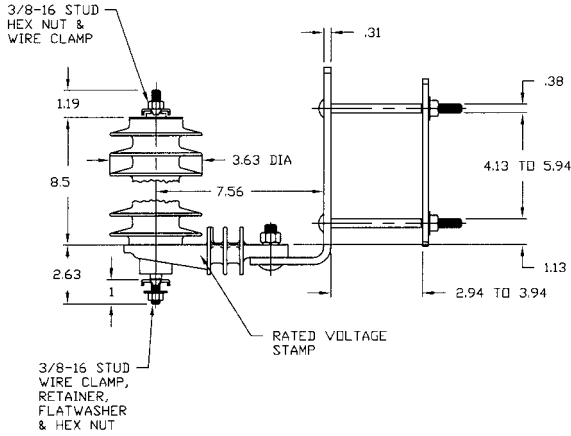

**PDV65-Optima**  
Catalog No. 2172657224

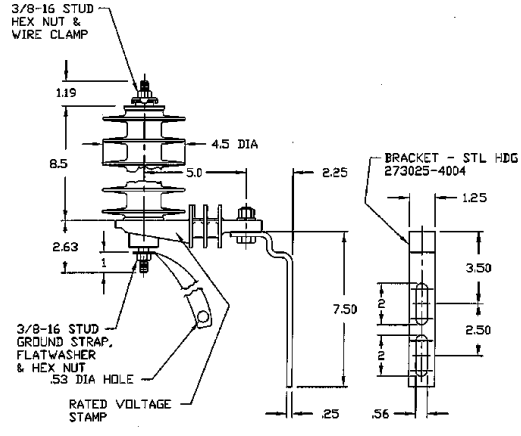

**PVR-Optima**  
Catalog No. 2216157233

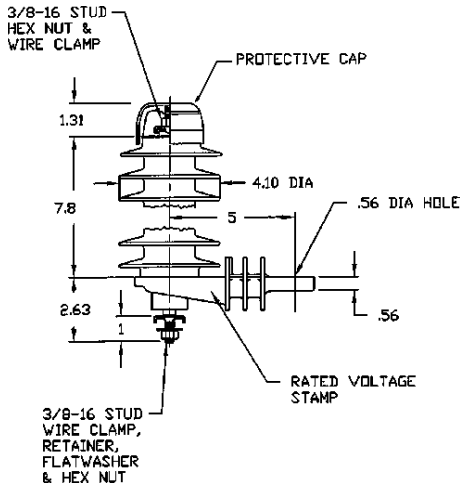

**PDV100-Optima**  
Catalog No. 2137157314

### RECOMMENDED TIGHTENING TORQUES FOR PDV ARRESTER FASTENERS

| Fastener  | Recommended Tightening Torque |
|---|-------------------------------|
| 3/8 inch line terminal  | 20 foot pounds                |
| 3/8 inch ground terminal  | 20 foot pounds                |
| 1/2 inch fastener connecting base bracket to crossarm or transformer sidewall bracket | 20 foot pounds                |

## Standard Mounting Brackets

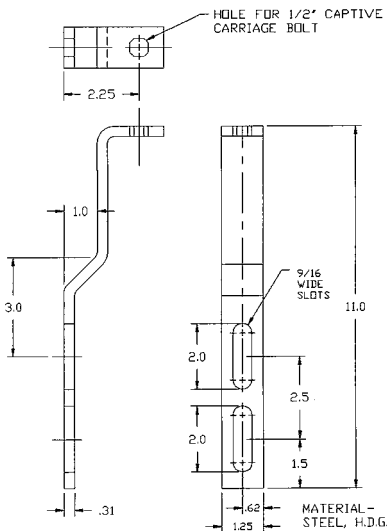

Transformer Mounting  
Part No. 2730664004

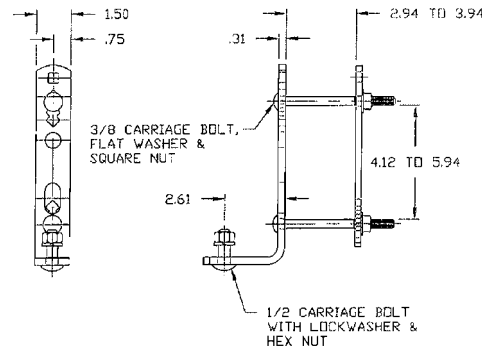

Crossarm Mounting  
Part No. 2734563001