

# DynaVar®

## IEC 5kA, 10kA Class 1 & Class 2 and IEEE Distribution & Riser Pole Surge Arresters



IEC 60099-4 TESTED  
IEEE C62.11 TESTED

Web: <http://www.hubbellpowersystems.com>  
E-mail: [hpsliterature@hps.hubbell.com](mailto:hpsliterature@hps.hubbell.com)

**BUSHINGS • CONSTRUCTION • INSULATION • PROTECTION • SWITCHING • TOOLS**

**Table of Contents**

	Page
Warranty .....	70-2
Introduction .....	70-3
Basic Construction .....	70-3
Rating Selection Considerations .....	70-4
Design Characteristics .....	70-5
Routine Production Tests .....	70-8
PDV-65 5 kA IEC .....	70-10
PDV-100 10kA IEC Class 1 .....	70-11
PVI-LP 10 kA IEC Class 2 .....	70-12
PDV65-Optima 5 kA IEEE Normal Duty .....	70-13
PDV100-Optima 10 kA IEEE Heavy Duty .....	70-14
PVR-Optima 10 kA IEEE Riser Pole .....	70-15

**Warranty - Material**

Hubbell Power Systems, Inc. warrants all products sold by it to be merchantable (as such term is defined in the Uniform Commercial Code) and to be free from defects in material and workmanship. Buyer must notify the Company promptly of any claim under this warranty. The Buyer's exclusive remedy for breach of this warranty shall be the repair or replacement, F.O.B. factory, at the Company's option, of any product defective under the warranty which is returned to the Company within one year from the date of shipment. NO OTHER WARRANTY, WHETHER EXPRESS OR ARISING BY OPERATION OF LAW, COURSE OF DEALING, USAGE OF TRADE OR OTHERWISE IMPLIED, SHALL EXIST IN CONNECTION WITH THE COMPANY'S PRODUCTS OR ANY SALE OR USE THEREOF. The Company shall in no event be liable for any loss of profits or any consequential or special damages incurred by Buyer. The Company's warranty shall run only to the first Buyer of a product from the Company, from the Company's distributor, or from an original equipment manufacturer reselling the Company's product, and is non-assignable and non-transferable and shall be of no force and effect if asserted by any person other than such first Buyer. This warranty applies only to the use of the product as intended by Seller and does not cover any misapplication or misuse of said product.

**Warranty - Application**

Hubbell Power Systems, Inc. does not warrant the accuracy of and results from product or system performance recommendations resulting from any engineering analysis or study. This applies regardless of whether a charge is made for the recommendation, or if it is provided free of charge.

Responsibility for selection of the proper product or application rests solely with the purchaser. In the event of errors or inaccuracies determined to be caused by Hubbell Power Systems, Inc., its liability will be limited to the re-performance of any such analysis or study.

**NOTE:**

Because Hubbell has a policy of continuous product improvement, we reserve the right to change design and specifications without notice.

©Copyright 2009 Hubbell/Ohio Brass

## Introduction

Ohio Brass introduced the very first U.S. non-ceramic arrester in 1986 and continues to be the market leader with a full line of polymer arresters for distribution voltages. Figure A portrays this broad offering of arresters for both the IEC and IEEE distribution markets. The PDV-65 offers cost effective protection for a normal duty arrester. The PDV-100 serves the IEC Class 1 arrester market. The newest in the line, Optima adds a new disconnecter which improves system reliability and increases TOV capability. The PVR-Optima targets cable applications and the PVI-LP® is our IEC Class 2 offering. As a market leader in arrester technology since 1950, Ohio Brass has a proven track record of advanced arrester technology, distinguished product quality, and extraordinary customer support that establishes Ohio Brass as a premier manufacturer of arrester products.

## Basic Construction

Each PDV, PVI-LP and PVR arrester is made up of a series of varistor blocks that are manufactured by Ohio Brass in our two state-of-the-art plants located in Ohio and South Carolina. Ohio Brass has many years of experience and proven ability in manufacturing these Metal Oxide Varistors

(MOVs), and this in-company capacity allows us to fully control the quality and manufacturing processes. These MOVs dictate the performance characteristics of the arrester and are locked in place with tightly wound layers of fiberglass filament impregnated with epoxy resin.

## Polymer Housing

The arrester housing is made from our proprietary blend of ESP™ silicone alloy. In addition to ESP™'s exceptional performance as an insulator material, ESP's properties have been confirmed in a series of performance tests that include tracking resistance, contamination, aging, and seal design.

## Mounting

The PDV, PVR and PVI-LP arresters can be used with all standard mounting arms and brackets. They are also supplied with all the necessary fasteners, isolators, and terminal attachments. A specially designed fiberglass-filled polyester insulating bracket, with integrated disconnecter, along with optional mounting brackets such as the cross arm or transformer bracket, enable mounting options that best suit every individual customer.

**Figure A: Distribution Arrester Offerings**

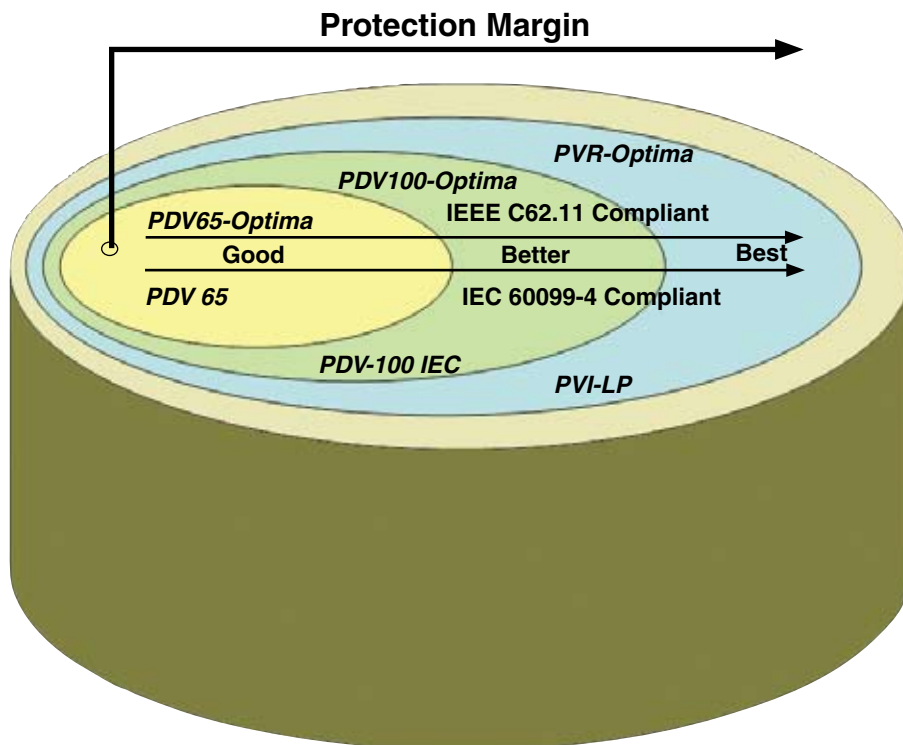
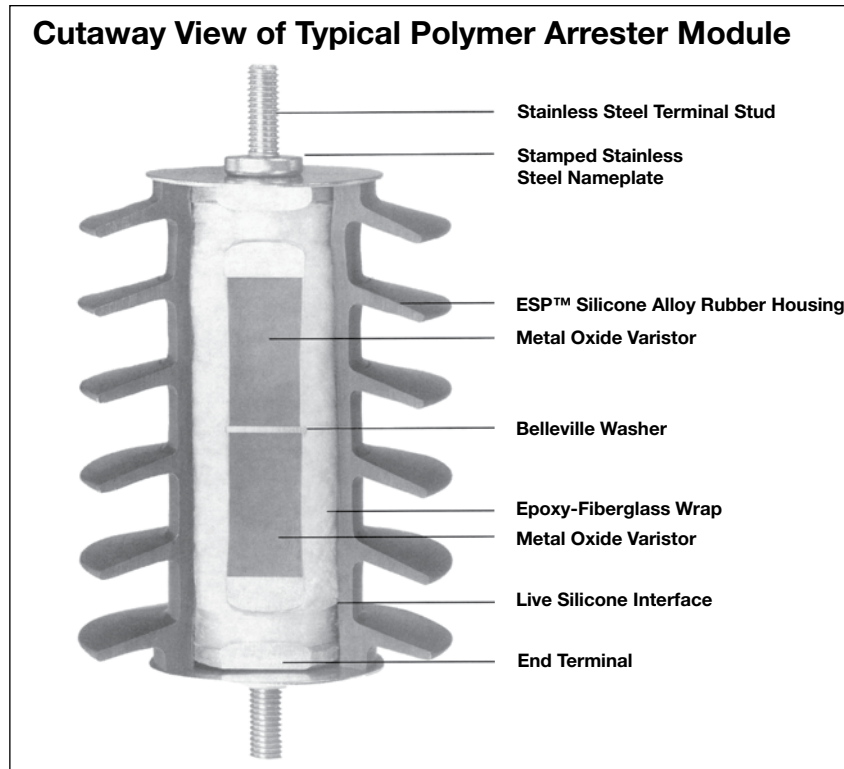

Figure B: Cutaway View of Typical Unit



### Rating Selection Considerations

Selection of arrester is based upon the continuous operating voltage (COV or  $U_c$ ) that is applied across the arrester in service (line-to-ground). For arresters on effectively grounded systems, this is normally the maximum line-to-ground voltage — e.g., 7.65 kV on a 12.47 kV multi-grounded system. For ungrounded or impedance-grounded systems, the  $U_c$  should be 90 percent of maximum phase-to-phase voltage or larger. Smaller arresters than shown may be used. Contact your Ohio Brass representative for details.

For convenience, the data shown in this catalog includes the traditional duty-cycle voltage rating associated with the  $U_c$  of each arrester. The selection of the actual type will be primarily governed by the insulation being protected. Following topics discuss important arrester design parameters.

**Table 1: Energy Capability**

Arrester Type	Max. Energy Discharge Capability kJ/kV - $U_c$
PDV-65	1.4
PDV-100	2.2
PVI-LP	3.4
PDV65-Optima	1.2
PDV100-Optima	1.8
PVR-Optima	2.2

Note: Based on single impulse test

**Table 2: Normally Recommended  $U_c$  for Various System Voltages**

System Line-to-Line Voltage (kV)		Arrester $U_c$ (kV)	
Nominal	Maximum	Effectively Grounded Neutral Circuit	Impedance Grounded & Ungrounded Circuits*
2.40	2.54	2.55	2.55
4.16	4.40	2.55	5.10
4.80	5.08	5.10	5.10
6.90	7.26	5.10	7.65
11.00	11.60	7.65	12.70
12.00	12.70	7.65	12.70
12.47	13.20	7.65	15.30
13.20	13.97	8.40	15.30
13.80	14.52	8.40	15.30
20.78	22.00	12.70	22.00
22.00	23.30	15.30	24.40
22.86	24.20	15.30	24.40
23.00	24.34	15.30	24.40
24.94	26.40	15.30	29.00
33.00	34.90	22.00	N/A
34.50	36.51	22.00	N/A

\*Depending on System Grounding conditions, it may be possible to use a lower rating. Consult your Hubbell Power Systems Representative for further information.

## Design Characteristics

**1. Long Duration Current Impulse:** Depending upon the system impedance and system conditions, power lines can discharge currents of low magnitude for significantly long durations as compared to a lightning stroke. The Ohio Brass MOV blocks are tailored to meet this challenge. MOV block samples are subjected to 18 to 20 discharges each with a current magnitude and duration as listed on Table 3 with one minute cooling interval between each discharge. The sample discharge voltages are verified before and after long duration discharges with a 10 kA 8/20  $\mu$ s current wave to confirm no damage. Table 3 shows that the actual changes are well below the tolerances allowed by standards, thus demonstrating product excellence.

**Table 3: Long Duration Current Impulse Compliance**

Standard	Product	Current (A)	Duration ( $\mu$ s)	Allowed Discharge Tolerance (%)	Actual Discharge Tolerance (%)
IEC 60099-4	PDV-65	75	2000	5%	4.0%
IEC 60099-4	PDV-100	230	2000	5%	1.5%
IEC 60099-4	PVI-LP	550	2000	5%	0.1%
IEEE C62.11	PDV65-Optima	75	2000	5%	0.2%
IEEE C62.11	PDV100-Optima	250	2000	5%	0.1%
IEEE C62.11	PVR-Optima	250	2000	10%	1.2%

**2. Accelerated Aging:** Ensuring stable arrester performance, after installation, is a necessity. MOV blocks are thermally aged at 115°C for 1000 hours at voltages specified by standards while continuous measurements of disc watts loss are recorded. Excellent stability is demonstrated with a continuous reduction in watts loss for the entire test period.

**Table 4: Accelerated Aging Performance**

Standard	Product	Temperature (°C)	Time (hrs)	Watts Loss
IEC 60099-4	PDV-65	130	1000	Continuously Decreasing
IEC 60099-4	PDV-100	111	1000	Continuously Decreasing
IEC 60099-4	PVI-LP	115	1000	Continuously Decreasing
IEEE C.62.11	PDV65-Optima	115	1000	Continuously Decreasing
IEEE C.62.11	PDV100-Optima	115	1000	Continuously Decreasing
IEEE C.62.11	PVR-Optima	115	1000	Continuously Decreasing

**3. Heat Dissipation Behavior:** The intent of this test is to ensure that the prorated test sample used for durability design tests has a thermal cooling characteristic that is slower than or equal to the actual unit. All prorated samples showed a slower cooling rate than a complete unit, demonstrating sample validity.

**4. Operating Duty Performance:** Distribution systems are affected more by lightning strokes than switching operations. The probability of the number of strokes and the magnitude of these strokes depend upon several factors that cannot be controlled or predicted accurately. Dynavar<sup>®</sup> arresters are tested to ensure they are capable of withstanding high current impulses while demonstrating thermal recovery. During this test, the MOV test samples are subjected to twenty 8/20  $\mu$ s lightning strokes and two 4/10  $\mu$ s high current impulses of specified magnitude followed by another 8/20  $\mu$ s discharge voltage verification impulse. The prorated sections demonstrated thermal stability. Table 5 compares the actual performance of the prorated sections under these test conditions with the tolerances permitted by the standards. It is evident that the arrester designs performed much superior to standard requirements.

**Table 5: Operating Duty Test Characteristics**

Standard	Product	Two , 4/10 $\mu$ s Current Waves (kA)	Allowed Discharge Tolerance (%)	Actual Discharge Tolerance (%)
IEC 60099-4	PDV-65	65	5.00%	0.38%
IEC 60099-4	PDV-100	100	5.00%	2.65%
IEC 60099-4	PVI-LP	100	5.00%	3.00%
IEEE C62.11	PDV65-Optima	65	10.00%	1.50%
IEEE C62.11	PDV100-Optima	100	10.00%	1.60%
IEEE C62.11	PVR-Optima	100	10.00%	1.30%

**5. Disconnecter Operation:** It is a common utility practice to attach a ground lead disconnecter to distribution arresters. This is done to ensure continuous system operation in the rare event of an arrester short circuit and to provide a visual indication of the disconnected unit. It is also important to verify that the disconnecter does not operate under surge conditions but isolates the ground lead during arrester short circuit. Samples with disconnecters were subjected to low current long duration tests and duty cycle/operating duty tests as summarized in Tables 3 and 5 to verify normal arrester operation under surge conditions. The disconnecter operation under faulted condition was also verified. Table 6, specifies the current sensitivity and the time response of the standard disconnecter. Standards specify the detonation curve be defined for fault currents ranging from 20 to 800 Amps.

Utilities have identified the necessity to have a more sensitive disconnecter that isolates the ground lead at lower current levels. Ohio Brass now offers its advanced disconnecter with all its IEEE C62.11 compliant Optima distribution arresters. Table 7 specifies the characteristics of the Optima disconnecter. The disconnecter will isolate the ground lead at currents as low as 1 A. This has been achieved with a patented capacitor-based disconnecter design instead of the traditional resistor designs. The capacitor-based isolator is more reliable as it prevents thermal run away situations that might be possible with commonly available resistor designs.

**Table 6: Standard Disconnecter Characteristics**

Normal Disconnecter	
Current Sensitivity (A)	Time to respond (s)
20	1.00
100	0.30
200	0.20
800	0.05

**Table 7: Optima Disconnecter Characteristics**

Optima Disconnecter	
Current Sensitivity (A)	Time to Respond (s)
1	7.00
10	1.50
20	0.80
100	0.28
200	0.18
800	0.05

**6. Power Frequency Voltage versus Time Characteristics:** Power systems are not ideal and periodically have temporary over voltages (TOV) caused by a variety of reasons. The magnitude and duration of the system-generated TOV that the arrester can withstand is best expressed graphically. The three curves on page 7 show the TOV capability versus time for the Ohio Brass arresters in this catalog.

The Optima utilizes a capacitance-based isolator which improves the TOV capability while increasing the reliability of disconnecter function. The Optima technology results in a family of TOV curves that are a function of the voltage  $U_c$  of the arrester.

For more information, contact your Ohio Brass sales representative.

**7. Partial Discharge Performance:** Partial discharges in arresters can result in radio interferences and initiate material fatigue that can reduce the life of arresters. Both the IEC 60099-4 and IEEE C62.11 standards require that the arrester shall demonstrate a partial discharge value of less than 10pC. All Ohio Brass arresters, comply with the standards.

**8. Pressure Relief Capability:** Ohio Brass arresters are designed such that, during an unlikely condition of a short circuit, they demonstrate sufficient explosion proof and shatter resistant properties. It is important to consider both the symmetrical R.M.S capability as well as the asymmetrical peak capability depending on system X/R conditions. Table 8 displays the demonstrated high and low symmetrical RMS current withstands and their durations. Table 8 also outlays the asymmetrical peak withstand and its duration. It can be observed that the asymmetrical peak to the symmetrical peak ratios are greater than 2.5.

### IEC TOV Capability with prior duty

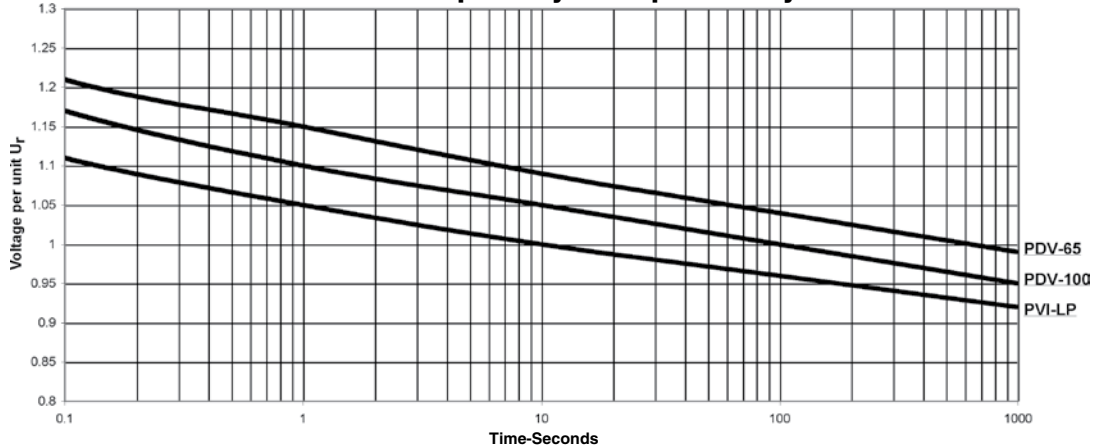

### ANSI TOV Capability with no bracket, No Prior Duty

ANSI No Prior Duty TOV Curves, Distribution Arresters Without Optima Bracket

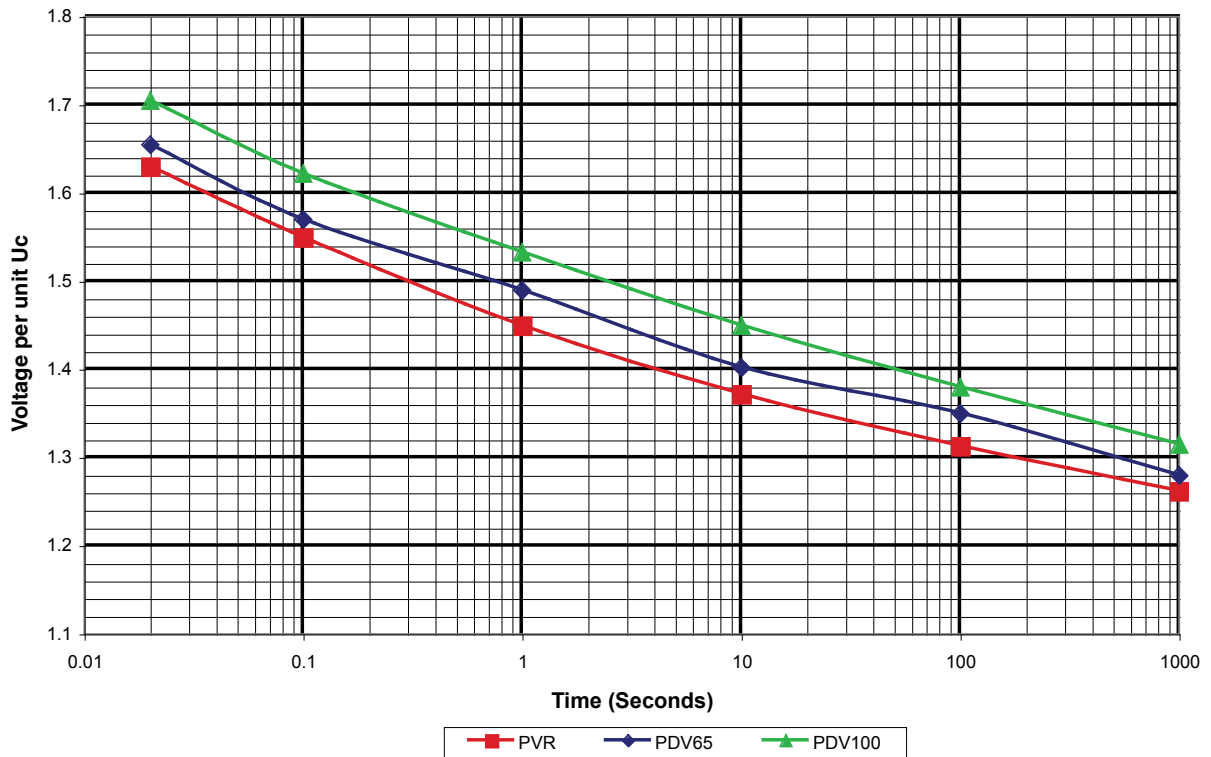

For ANSI Optima products, refer to online Design Test Reports: EU1415 for PDV65, EU1512 for PDV100, and EU1480 for PVR on the Hubbell Power Systems website: [www.hubbellpowersystems.com/powertest/literature-library/pdflib\\_design.html](http://www.hubbellpowersystems.com/powertest/literature-library/pdflib_design.html)

**Table 8: Symmetrical & Asymmetrical Pressure Relief Capability**

Standard	Product	High Symmetrical RMS (A) and Duration (s)	Low Symmetrical RMS (A) and Duration (s)	Asymmetrical Peak (A)	Duration (s)
IEC 60099-4	PDV-65	15,000A & 0.2s	600A & 1s	38,250	0.2
IEC 60099-4	PDV-100	20,000A & 0.2s	2020A & 1s	50,000	0.2
IEC 60099-4	PVI-LP	41,000A & 0.2s	600A & 1s	107,000	0.2
IEEE C62.11	PDV65-Optima	15,000A & 0.2s	600A & 1s	38,250	0.2
IEEE C62.11	PDV100-Optima	20,000A & 0.2s	600A & 1s	55,300	0.2
IEEE C62.11	PVR-Optima	20,000A & 0.2s	600A & 1s	50,000	0.2

## Routine Production Tests

Ohio Brass maintains stringent testing controls in accordance with IEC 60099-4 to ensure that the customer receives consistent quality with every product. Ohio Brass also performs various Quality Assurance tests on every batch of MOV blocks. The routine tests listed below, in addition to highly controlled manufacturing processes, ensure that Ohio Brass products demonstrate a superior level of quality.

### MOV Block Routine Tests:

- **Physical Inspection** – Visual tests are performed post grind, post energy test, and for a final visual inspection.
- **Rated Energy Test** – This procedure confirms the energy capability of each zinc oxide disc element.
- **Discharge Voltage Test** – Every block undergoes an 8/20 current wave impulse to verify its V-I characteristics.
- **Watts Loss Test** – This test measures the AC watts loss and capacitive current characteristics of the disc.

### MOV Block Batch QA Tests:

- **Square Wave Energy Test** – Performed on a 5 disc sample from each batch, this test is performed to quantify the batch energy capability.
- **High Current Test** – Each 5 disc sample is subjected to two high current discharges of the same polarity to ensure high current characteristics.
- **AC Life Test** – The discs are placed under test conditions for a minimum of 250 hours to verify performance.

### Arrester Routine Tests:

- **Physical Inspection** – Every molded rubber part, block, wrap module, bracket and completed unit is visually examined to reject defective products.
- **Reference Voltage Test** – This test measures the voltage once a predetermined maximum peak current is reached.
- **Partial Discharge Test** – This test ensures that the partial discharge level of the arrester does not exceed a level of 10 pC.

## Arrester Mechanical Working Values

**Mechanical parameters:** The conservative mechanical working values shown in Table 9 are for the arrester unit itself. As can be observed, these values are in excess of common requirements. For values of arresters with insulating brackets or any other special condition, please contact your Ohio Brass account representative.

**Table 9: Mechanical Working Values of Arresters**

Tension		Cantilever Moment	Tension	Torsion	Compression
Standard	Product	NM	N	NM	N
IEC 60099-4	PDV-65	27	680	27	680
IEC 60099-4	PDV-100	135	908	27	908
IEC 60099-4	PVI-LP	128	1360	54	1360
IEEE C.62.11	PDV65-Optima	45	680	27	680
IEEE C.62.11	PDV100-Optima	80	908	27	908
IEEE C.62.11	PVR-Optima	135	1360	54	1360

## Arrester Accessories & Ordering Information

**Insulating Base Brackets:** Utilities can cut the cost of providing a standoff insulator for arrester support by choosing the cost effective optional insulating base bracket along with the arrester. Table 10 illustrates the electrical parameters. Table 11 shows the standard brackets for each Ohio Brass arrester. Page 70-9 shows the drawings for the available insulating base brackets. For special locations with extreme contamination levels, please contact your Ohio Brass representative for additional bracket and hardware options.

**Table 10: Insulating Bracket Electrical Parameters**

Bracket Type	Insulation withstand (kV)		
	BIL (kV)	Power Frequency Withstand(kV)	
		Dry	Wet
Short	75	40	20
Medium	80	45	25
Long	95	50	30

**Table 11: Standard Bracket Selection Criteria**

Bracket Size	Insulation withstand (kV)	
	U <sub>c</sub> Range (kV)	Rating Range (kV)
Short	2.55 to 10.2	3 to 12
Medium	12.7 to 19.5	15 to 24
Long	22 to 29*	27 to 36*

\*Note: (\*) PDV-100 has higher kV range.

Note: Arrester bracket ranges reflect minimum bracket requirements.

### Bracket Drawings

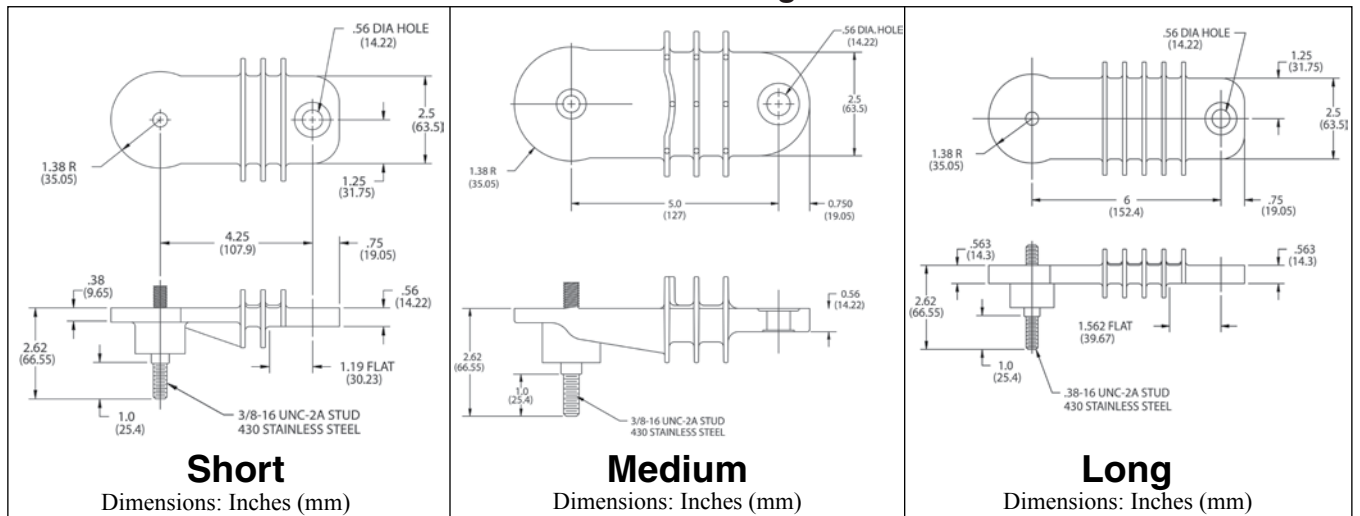

**Ordering your arrester:** Arresters are identified by their 10 digit part numbers. Choose the appropriate first six digits of the arrester shown in the "Catalog Number" column of the electrical characteristics table in the following pages. Based on the hardware configuration, please select your choice of the last four digits. Table 12 shows the available hardware for each arrester group. Ex: For an IEC PDV-100 arrester of 8.4 kV  $U_c$  without any hardware, the catalog number would be 214210-CCAA. For an IEEE PDV100-Optima of 8.4 kV  $U_c$  with basic hardware the catalog number is 213709-7202.

**Table 12: Available Arrester Hardware**

Standard	Product	Prefix Codes	US Hardware Configuration	Metric Hardware Configuration	Page
IEEE C62.11	PDV65-Optima	See Table 21	✓		13
IEEE C62.11	PDV100-Optima	2137XX	✓		14
IEEE C62.11	PVR-Optima	2216XX	✓		15
IEC60099-4	PDV-65	2133XX	See Note		10
IEC60099-4	PDV-100	2132XX	✓		11
IEC60099-4	PVI-LP	2184XX	✓		12
IEC60099-4	PDV-65	2140XX		See Note	10
IEC60099-4	PDV-100	2142XX		✓	11
IEC60099-4	PVI-LP	2145XX		✓	12

**Table 13: Common U.S. Hardware Configurations**

Suffix	Top Hardware	Mounting Hardware	Bottom Hardware
7202	Hex Nut & Wire Clamp	None	Hex Nut, Wire Clamp, Flatwasher
7213	Hex Nut & Wire Clamp	Insulated Base Bracket	Isolator, Hex Nut & Ground Strap
7214	Hex Nut & Wire Clamp	Insulated Base Bracket	Isolator, Hex Nut & Wire Clamp
7224	Hex Nut & Wire Clamp	Insulated Base Bracket & NEMA 4x5 X-Arm Bracket	Isolator, Hex Nut & Wire Clamp
7234	Hex Nut & Wire Clamp	Insulated Base Bracket & Transformer Bracket	Isolator, Hex Nut & Wire Clamp
7233	Hex Nut & Wire Clamp	Insulated Base Bracket & Transformer Bracket	Isolator, Hex Nut & Ground Strap
7313	Hex Nut, Wire Clamp, & Protective Cap	Insulated Base Bracket	Isolator, Hex Nut & Ground Strap
7314	Hex Nut, Wire Clamp, & Protective Cap	Insulated Base Bracket	Isolator, Hex Nut & Wire Clamp
7324	Hex Nut, Wire Clamp, & Protective Cap	Insulated Base Bracket & NEMA 4x5 X-Arm Bracket	Isolator, Hex Nut & Wire Clamp
7334	Hex Nut, Wire Clamp, & Protective Cap	Insulated Base Bracket & Transformer Bracket	Isolator, Hex Nut & Wire Clamp
7333	Hex Nut, Wire Clamp, & Protective Cap	Insulated Base Bracket & Transformer Bracket	Isolator, Hex Nut & Ground Strap
7533	Hex Nut, Wire Clamp, Protective Cap, & 18" Lead Wire	Insulated Base Bracket & Transformer Bracket	Isolator, Hex Nut & Ground Strap
7534	Hex Nut, Wire Clamp, Protective Cap, & 18" Lead Wire	Insulated Base Bracket & Transformer Bracket	Isolator, Hex Nut & Wire Clamp

**Table 14: Common Metric Hardware Configurations**

Suffix	Mounting Hardware	Top Hardware	Bottom Hardware
CCAA	No Bracket	No Accessories	No Accessories
CCBE	No Bracket, No Disconnecter	Hex Nut & Wire Clamp	Hex Nut, Wire Clamp & 2 Washers, No Isolator
CLBC*	Short Bracket with Disconnecter	Hex Nut & Wire Clamp	Hex Nut, Wire Clamp & Washer
C1BC*	Medium Bracket with Disconnecter	Hex Nut & Wire Clamp	Hex Nut, Wire Clamp & Washer
CVBC*	Long Bracket with Disconnecter	Hex Nut & Wire Clamp	Hex Nut, Wire Clamp & Washer

\*To add a protective cap, change the BC to CC

**NOTE:**  
PDV-65 arrester catalog number requires different voltage code depending on prefix. See Table 15.

## IEC 5 kA ARRESTER – PDV-65

The PDV-65 design satisfies the IEC 60099-4 5kA requirements. Table 15 specifies the electrical characteristics while Table 16 specifies the dimensions, weights, clearances and insulation characteristics of the arrester only configuration.

**Table 15: PDV-65 Electrical Characteristics**

U <sub>R</sub> Rated Voltage	U <sub>C</sub> Continuous Operating Voltage	Catalog Number		Residual Voltage U <sub>res</sub> (kV)								
		US hardware Prefix = 2133XX	Metric hardware Prefix = 2140XX	0.5μs Steep Front	8/20 μs Lightning Surge							60/100 Switching Surge
					10kA	1.5kA	3kA	5kA	10kA	20kA	40kA	
(kV)	(kV)	xx=	xx=	10kA	1.5kA	3kA	5kA	10kA	20kA	40kA	500A	
3	2.55	53	03	11.6	9.2	9.9	10.5	11.7	13.4	16.3	6.5	
6	5.1	55	05	23.1	18.5	19.8	21.0	23.3	26.8	32.6	17.1	
9	7.65	58	08	33.1	26.4	28.3	30.0	33.3	38.2	46.5	24.4	
10	8.4	59	09	34.7	27.7	29.7	31.5	35.0	40.1	48.8	25.6	
12	10.2	60	10	42.4	33.8	36.3	38.5	42.8	49.0	59.7	31.3	
15	12.7	63	13	54.0	43.1	46.3	49.0	54.4	62.4	76.0	39.9	
18	15.3	65	15	62.8	50.1	53.8	57.0	63.3	72.6	88.4	46.4	
21	17	67	17	68.3	54.5	58.5	62.0	68.9	79.0	96.1	50.5	
24	19.5	70	20	84.9	67.7	72.7	77.0	85.5	98.1	119.4	62.7	
27	22	72	22	96.4	76.9	82.6	87.5	97.2	111.5	135.6	71.2	
30	24.4	74	24	103.0	82.2	88.3	93.5	103.9	119.1	144.9	76.1	
36	29	79	29	122.3	97.6	104.8	111.0	123.3	141.4	172.1	90.4	

**Table 16: PDV-65 Dimensions, Clearances and Insulation Withstands**

U <sub>R</sub> Rated Voltage	U <sub>C</sub> Continuous Operating Voltage	Arrester Only Height (Y)	Minimum Leakage Distance	Minimum Strike Distance	Recommended Clearances		Weight	IEC Required BIL 1.3x 5kA IR	Actual BIL Arrester Only	500 Amp SS IR	IEC Required 60 Hz Wet WS 1.06x SS IR	Actual 60 Hz Wet WS Arrester Only
					Phase-Phase	Phase-Ground						
(kV)	(kV)	(mm)	(mm)	(mm)	(mm)	(mm)	(kg)	(kVc)	(kVc)	(kVc)	(kVc)	(kVc)
3	2.55	140	390	155	127	76	1.6	13.7	125	8.5	9	34
6	5.1	140	390	155	137	86	1.6	27.5	125	17.1	18	34
9	7.65	140	390	155	152	102	1.6	39.0	125	24.4	26	34
10	8.4	140	390	155	157	107	1.6	41.0	125	25.6	27	34
12	10.2	140	390	155	191	140	1.7	50.5	125	31.3	33	34
15	12.7	216	645	245	216	165	2.5	63.7	180	39.9	42	50
18	15.3	216	645	245	241	191	2.5	74.2	180	46.4	49	50
21	17	216	645	245	254	203	2.6	80.6	180	60.5	64	50
24	19.5	277	780	285	305	254	3.0	100.1	210	62.7	66	65
27	22	354	1035	360	330	279	4.0	113.8	230	71.2	75	82
30	24.4	354	1035	360	356	305	4.1	121.6	230	76.1	81	82
36	29	430	1290	450	419	368	4.8	144.3	250	90.4	96	100

For IEC Arresters

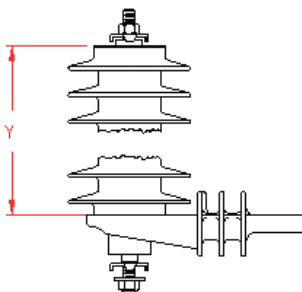

NOTE:

PDV-65 arrester catalog number requires different voltage code depending on prefix. See Table 15.

## IEC CLASS 1 ARRESTER – PDV-100

The PDV-100 design satisfies the IEC 60099-4 10kA Class 1 requirement. Table 17 specifies the electrical characteristics while Table 18 specifies the dimensions, weights, clearances and insulation characteristics of the arrester only configuration.

**Table 17: PDV-100 Electrical Characteristics**

U <sub>R</sub> Rated Voltage	U <sub>C</sub> Continuous Operating Voltage	Catalog Number (See Note)	Residual Voltage U <sub>res</sub> (kV)								
			0.5μs Steep Front	8/20 μs Lightning Surge						60/100 Switching Surge	
				10 kA	1.5 kA	3 kA	5 kA	10 kA	20 kA	40 kA	125 kA
kV	kV										
3	2.55	214203	10.9	8.0	8.7	9.1	10.1	11.6	13.7	6.8	7.3
6	5.1	214205	20.5	15.2	16.4	17.3	19.1	21.9	25.9	12.9	13.8
9	7.65	214208	29.5	21.8	23.5	24.8	27.4	31.4	37.1	18.5	19.9
10	8.4	214209	32.3	23.9	25.7	27.2	30.0	34.4	40.6	20.2	21.8
12	10.2	214210	38.3	28.3	30.5	32.2	35.6	40.8	48.2	24.0	25.8
15	12.7	214213	47.6	35.3	38.0	40.1	44.3	50.8	60.0	29.9	32.1
18	15.3	214215	56.7	41.9	45.2	47.7	52.7	60.4	71.4	35.5	38.2
21	17	214217	66.1	49.0	52.7	55.7	61.5	70.5	83.3	41.5	44.6
24	19.5	214220	76.6	56.8	61.1	64.5	71.3	81.8	96.5	48.1	51.7
27	22	214222	86.0	63.7	68.6	72.4	80.0	91.8	108.3	53.9	58.0
30	24.4	214224	95.7	70.8	76.3	80.5	89.0	102.1	120.5	60.0	64.5
36	29	214230	114.0	84.4	90.8	95.9	106.0	121.6	143.5	71.4	76.9
42	33	214233	132.2	97.9	105.4	111.3	123.0	141.1	166.5	82.9	89.2
45	36	214236	142.9	105.8	113.9	120.3	132.9	152.4	179.9	89.6	96.4
48	39	214240	153.1	113.4	122.0	128.9	142.4	163.3	192.8	96.0	103.2

**Table 18: PDV-100 Dimensions, Clearances and Insulation Withstands**

U <sub>R</sub> Rated Voltage	U <sub>C</sub> Continuous Operating Voltage	Catalog Number (See Note)	Arrester Only Height (Y)	Minimum Leakage Distance	Minimum Strike Distance	Recommended Clearances		Weight	IEC Required BIL 1.3x 10kA IR	Actual BIL Arrester Only	500 Amp SS IR	IEC Required 60 Hz Wet WS 1.06x SS IR	Actual 60 Hz Wet WS Arrester Only
						Phase-Phase	Phase-Ground						
						(mm)	(mm)						
(kV rms)	(kV rms)		(mm)	(mm)	(mm)	(mm)	(mm)	(kg)	(kVc)	(kVc)	(kVc)	(kVc)	(kVc)
3	2.55	214203	140	390	155	127	76	1.9	13.2	125	7.3	8	34
6	5.1	214205	140	390	155	137	86	1.9	24.9	125	13.8	15	34
9	7.65	214208	140	390	155	152	102	1.9	35.7	125	19.9	21	34
10	8.4	214209	140	390	155	157	107	1.9	39.0	125	21.8	23	34
12	10.2	214210	140	390	155	191	140	2.0	46.3	125	25.8	27	34
15	12.7	214213	216	660	245	216	165	2.6	57.6	180	32.1	34	50
18	15.3	214215	216	660	245	241	191	2.6	68.6	180	38.2	40	50
21	17	214217	216	660	245	254	203	2.8	80.0	180	44.6	47	50
24	19.5	214220	274	780	285	270	220	3.4	93.7	210	51.7	55	65
27	22	214222	437	1320	455	280	230	4.4	104.0	250	58.0	61	100
30	24.4	214227	437	1320	455	290	240	4.4	116.0	250	64.5	68	100
36	29	214230	437	1320	455	330	290	4.9	138.0	250	76.9	82	100
42	33	214233	437	1320	451	380	340	4.9	160.0	250	89.2	95	100
45	36	214236	643	1981	665	400	370	5.9	173.0	400	96.4	102	130
48	39	214240	643	1981	665	430	390	5.9	186.0	400	103.2	109	130

**NOTE:**

To order the IEC Class 1 PDV-100 with U.S. hardware, change the 2142XX to 2132XX. This option is shown in Table 12.

**For IEC Arresters**

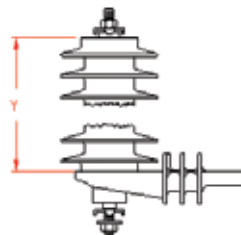

## IEC CLASS 2 ARRESTER – PVI-LP

The PVI-LP® design satisfies the IEC 60099-4 10kA Class 2 requirement. Table 19 specifies the electrical characteristics while Table 20 specifies the dimensions, weights, clearances and insulation characteristics of the arrester only configuration.

**Table 19: PVI-LP Electrical Characteristics**

U <sub>R</sub> Rated Voltage kV	U <sub>C</sub> Continuous Operating Voltage kV	Catalog Number (See Note)	Residual Voltage U <sub>res</sub> (kV)								
			0.5µs Steep Front	8/20 µs Lightning Surge						60/100 Switching Surge	
				10 kA	1.5 kA	3 kA	5 kA	10 kA	20 kA	40 kA	125 A
3	2.55	214503	8.6	6.8	7.2	7.5	8.1	9.0	10.1	5.9	6.4
6	5.1	214505	17.1	13.6	14.4	15.0	16.2	17.9	20.2	11.9	12.7
9	7.65	214508	25.8	20.5	21.6	22.6	24.4	27.0	30.4	17.9	19.1
10	8.4	214509	28.4	22.6	23.8	24.9	26.9	29.8	33.5	19.7	21.1
12	10.2	214510	34.1	27.1	28.6	29.9	32.3	35.8	40.3	23.7	25.3
15	12.7	214513	42.9	34.1	36.0	37.6	40.6	44.9	50.6	29.8	31.8
18	15.3	214515	51.6	40.9	43.2	45.2	48.8	54.0	60.9	35.8	38.3
21	17.0	214517	56.9	45.1	47.7	49.9	53.8	59.6	67.1	39.5	42.2
24	19.5	214520	68.3	54.2	57.2	59.9	64.6	71.5	80.6	47.4	50.6
27	22.0	214522	72.4	61.4	64.9	67.9	73.2	81.0	91.3	53.7	57.4
30	24.4	214524	85.3	67.7	71.5	74.8	80.7	89.3	101	59.2	63.3
36	29.0	214529	102.0	81.3	85.9	89.8	96.9	107.0	121	71.1	76.0

**Table 20: PVI-LP Dimensions, Clearances and Insulation Withstands**

U <sub>R</sub> Rated Voltage kV	U <sub>C</sub> Continuous Operating Voltage kV	Catalog Number (See Note)	Height Y mm	Creepage Distance mm	Recommended Clearances		Weight kg	Minimum Insulation Withstand (kV)	
					Phase-Phase mm	Phase-Ground mm		BIL 1.2/50	Power Frequency Withstand Wet
					mm	mm			
3	2.55	214503	140	391	127	76	2.1	10.5	6.8
6	5.1	214505	140	391	135	84	2.1	21.1	13.5
9	7.65	214508	140	391	147	97	2.1	31.7	20.2
10	8.4	214509	140	391	152	102	2.1	35.0	22.4
12	10.2	214510	140	391	185	135	2.1	42.0	26.8
15	12.7	214513	276	782	211	160	3.8	52.8	33.7
18	15.3	214515	276	782	234	183	3.8	63.4	40.6
21	17.0	214517	276	782	246	196	3.8	69.9	44.7
24	19.5	214520	276	782	295	244	3.8	84.0	53.6
27	22.0	214522	415	1173	318	267	5.6	95.2	60.8
30	24.4	214524	415	1173	343	292	5.6	104.9	67.1
36	29.0	214529	415	1173	406	356	5.6	126.0	80.6

### For IEC Arresters

**NOTE:**

To order the IEC Class 2 PVI-LP with U.S. hardware, change the 2145XX to 2184XX. This option is shown in Table 12.

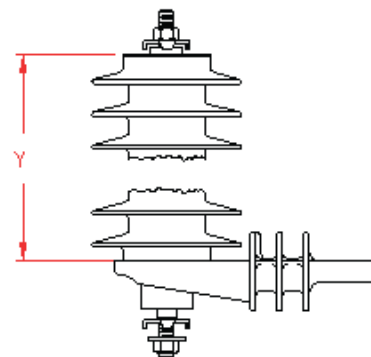

## IEEE NORMAL DUTY DISTRIBUTION ARRESTER – PDV65-Optima

The PDV65-Optima design satisfies the IEEE C62.11 normal-duty arrester requirement. Table 21 specifies the electrical characteristics while Table 22 specifies the dimensions, weights, clearances and insulation characteristics of the arrester only configuration.

**Table 21: PDV65-Optima Electrical Characteristics**

U <sub>R</sub> Rated Voltage	U <sub>C</sub> Continuous Operating Voltage	Catalog Number	Residual Voltage U <sub>res</sub> (kV)							
			0.5μs Steep Front	8/20 μs Lightning Surge						60/100 Switching Surge
				10kA	1.5 kA	3 kA	5 kA	10 kA	20 kA	
kV	kV									
3	2.55	217253	12.5	9.8	10.3	11.0	12.3	14.3	18.5	8.5
6	5.1	217255	25.0	19.5	20.5	22.0	24.5	28.5	37.0	17.0
9	7.65	217258	33.5	26.0	28.0	30.0	33.0	39.0	50.5	23.5
10	8.4	217259	36.0	27.0	29.5	31.5	36.0	41.5	53.0	25.4
12	10.2	217560	42.4	33.8	36.3	38.5	42.8	49.0	60.9	31.3
15	12.7	213263	54.0	43.1	46.3	49.0	54.4	62.4	78.0	39.9
18	15.3	213265	62.8	50.1	53.8	57.0	63.3	72.6	91.2	46.4
21	17.0	213267	68.3	54.5	58.5	62.0	68.9	79.0	98.3	50.5
24	19.5	217570	84.8	67.6	72.6	77.0	85.6	98.0	121.9	62.6
27	22.0	213272	96.4	76.9	82.6	87.5	97.2	111.4	139.0	71.2
30	24.4	213274	104.3	81.5	88.0	93.5	104.9	120.5	149.1	74.5
36	29.0	213279	125.6	100.2	107.6	114.0	126.7	145.2	176.7	92.8

**Table 22: PDV65-Optima Dimensions, Clearances and Insulation Withstands**

U <sub>R</sub> Rated Voltage	U <sub>C</sub> Continuous Operating Voltage	Catalog Number	Height X	Creepage Distance	Recommended clearances		Weight	Insulation Withstand (kV)	
					Phase-Phase	Phase-Ground		BIL (kV)	Power Frequency Withstand
					mm	mm		mm	mm
3	2.55	217253	236	391	122	76	1.6	20.3	9.9
6	5.1	217255	236	391	127	81	1.6	40.5	19.8
9	7.65	217258	236	391	142	97	1.6	55.4	29.7
10	8.4	217259	236	391	147	104	1.6	58.9	32.7
12	10.2	217560	236	391	191	145	1.6	80.9	39.7
15	12.7	213263	312	647	216	170	2.4	88.6	49.4
18	15.3	213265	312	647	241	196	2.4	103.1	59.5
21	17.0	213267	312	647	254	208	2.4	112.2	66.1
24	19.5	217570	374	782	305	259	3.5	139.3	75.8
27	22.0	213272	450	1038	330	284	3.5	158.3	85.5
30	24.4	213274	450	1038	345	300	3.5	172.8	94.9
36	29.0	213279	525	1295	411	366	4.2	221.5	112.8

### For ANSI/IEEE Arresters

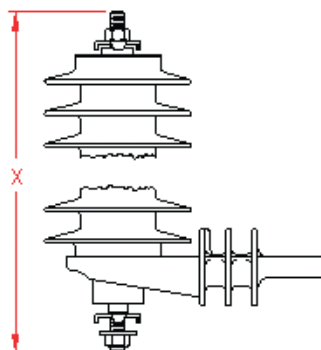

## IEEE HEAVY DUTY DISTRIBUTION ARRESTER – PDV100-Optima

The PDV100-Optima design satisfies the IEEE C62.11 heavy-duty arrester requirement. Table 23 specifies the electrical characteristics while Table 24 specifies the dimensions, weights, clearances and insulation characteristics of the arrester only configuration.

**Table 23: PDV100-Optima Electrical Characteristics**

U <sub>R</sub> Rated Voltage	U <sub>C</sub> Continuous Operating Voltage	Catalog Number	Residual Voltage U <sub>res</sub> (kV)							45/90 Switching Surge
			0.5μs Steep Front	8/20 μs Lightning Surge					500 A	
				10 kA	1.5 kA	3 kA	5 kA	10 kA		
kV	kV		10 kA	1.5 kA	3 kA	5 kA	10 kA	20 kA	40 kA	500 A
3	2.55	213703	10.6	8.0	8.5	9.0	9.9	11.1	13.2	7.6
6	5.1	213705	21.3	15.9	17.0	18.0	19.8	22.3	26.5	15.3
9	7.65	213708	31.2	23.3	24.9	26.4	29.0	32.6	38.8	22.4
10	8.4	213709	34.0	25.4	27.1	28.8	31.6	35.6	42.3	24.4
12	10.2	213710	40.4	30.3	32.3	34.2	37.6	42.3	50.3	29.0
15	12.7	213713	51.4	38.5	41.1	43.5	47.8	53.8	64.0	36.9
18	15.3	213715	60.6	45.4	48.4	51.3	56.4	63.5	75.5	43.5
21	17.0	213717	68.3	51.1	54.5	57.8	63.5	71.4	85.0	49.0
24	19.5	213720	81.9	61.3	65.5	69.3	76.2	85.7	102.0	58.8
27	22.0	213722	91.9	68.8	73.4	77.8	85.5	96.2	114.4	65.9
30	24.4	213724	101.1	75.7	80.7	85.5	94.0	105.8	125.8	72.5
36	29.0	213729	121.4	97.9	97.0	102.7	112.9	127.0	151.1	87.0

**Table 24: PDV100-Optima Dimensions, Clearances and Insulation Withstands**

U <sub>R</sub> Rated Voltage	U <sub>C</sub> Continuous Operating Voltage	Catalog Number	Height X	Creepage Distance	Recommended Clearances		Weight	Insulation Withstand (kV)	
					Phase- Phase	Phase- Ground		BIL	Power Frequency Withstand
					mm	mm		mm	mm
kV	kV		mm	mm	mm	mm	kg	1.2/50	Wet
3	2.55	213703	173	216	127	76	1.3	15.8	7.8
6	5.1	213705	193	287	137	86	1.5	31.7	15.7
9	7.65	213708	221	366	152	102	1.7	46.3	22.1
10	8.4	213709	221	366	157	107	1.7	50.6	24.2
12	10.2	213710	236	432	191	140	2.0	60.1	28.5
15	12.7	213713	295	640	216	165	2.5	76.4	35.5
18	15.3	213715	295	640	241	191	2.5	90.2	42.8
21	17.0	213717	315	714	254	203	2.8	101.4	47.6
24	19.5	213720	389	927	305	254	3.8	121.7	54.6
27	22.0	213722	417	1006	330	279	4.0	136.6	61.6
30	24.4	213724	429	1072	356	305	4.2	150.2	68.3
36	29.0	213729	490	1280	419	368	4.7	180.3	81.1

### For ANSI/IEEE Arresters

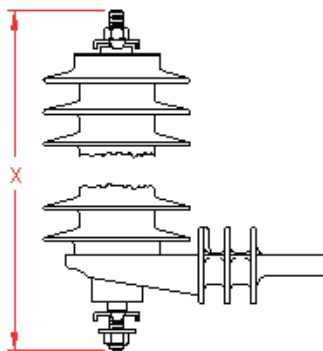

## IEEE RISER POLE DISTRIBUTION ARRESTER – PVR-Optima

The PVR-Optima design satisfies the IEEE C62.11 riser pole heavy-duty arrester requirement. Table 25 specifies the electrical characteristics while Table 26 specifies the dimensions, weights, clearances and insulation characteristics of the arrester only configuration.

**Table 25: PVR-Optima Electrical Characteristics**

U <sub>R</sub> Rated Voltage	U <sub>C</sub> Continuous Operating Voltage	Catalog Number	Residual Voltage U <sub>res</sub> (kV)							
			0.5μs Steep Front	8/20 μs Lightning Surge						45/90 Switching Surge
				10 kA	1.5 kA	3 kA	5 kA	10 kA	20 kA	
kV	kV									
3	2.55	221603	9.9	7.2	7.8	8.2	9.1	10.4	12.3	6.6
6	5.1	221605	20.0	14.6	15.7	16.6	18.3	21.0	24.8	13.3
9	7.65	221608	26.8	19.5	21.0	22.2	24.5	28.1	33.2	17.8
10	8.4	221609	29.5	21.5	23.1	24.4	27.0	31.0	36.6	19.6
12	10.2	221610	35.5	25.9	27.9	29.4	32.5	37.3	44.0	23.6
15	12.7	221613	44.2	32.2	34.7	36.7	40.5	46.5	54.8	29.4
18	15.3	221615	53.4	38.9	41.9	44.3	48.9	56.1	66.2	35.5
21	17.0	221617	60.7	44.3	47.6	50.3	55.6	63.8	75.3	40.3
24	19.5	221620	70.9	51.7	55.6	58.7	64.9	74.4	87.9	47.1
27	22.0	221622	78.6	57.3	61.7	65.2	72.0	82.6	97.5	52.2
30	24.4	221624	88.5	64.5	69.4	73.3	81.0	92.9	110.0	58.7
36	29.0	221629	105.0	76.5	82.4	87.0	96.1	110.0	130.0	69.7

**Table 26: PVR-Optima Dimensions, Clearances and Insulation Withstands**

U <sub>R</sub> Rated Voltage	U <sub>C</sub> Continuous Operating Voltage	Catalog Number	Height X	Creepage Distance	Recommended Clearances		Weight	Insulation Withstand (kV)	
					Phase-Phase	Phase-Ground		BIL	Power Frequency Withstand
					mm	mm			
kV	kV		mm	mm	mm	mm	kg		
3	2.55	221603	178	203	127	76	1.5	15.8	6.7
6	5.1	221605	239	391	135	84	1.9	31.7	13.4
9	7.65	221608	239	391	147	97	1.9	46.3	20.2
10	8.4	221609	239	391	152	102	1.9	50.6	22.1
12	10.2	221610	239	391	185	135	2.0	60.1	26.9
15	12.7	221613	315	660	211	160	2.5	76.4	33.5
18	15.3	221615	315	660	234	183	2.8	90.2	40.3
21	17.0	221617	315	660	246	196	2.8	101.4	44.8
24	19.5	221620	373	782	295	244	3.4	121.7	51.4
27	22.0	221622	536	1321	318	267	4.4	136.6	58.0
30	24.4	221624	536	1321	343	292	4.4	150.2	64.3
36	29.0	221629	536	1321	406	356	4.9	180.3	76.4

### For ANSI/IEEE Arresters

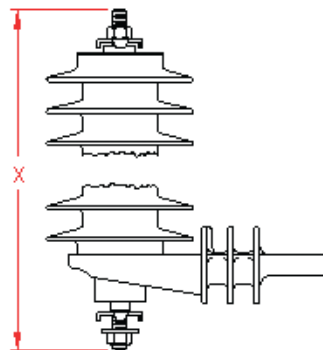

**Protective Caps**

**Universal Optima Cap:** The new Optima line end protective cap shown is designed for single or through connection lead wires. Each side of the cap has webbed fingers that prevent accidental contact with the arrester top end hardware by wildlife.



**Arrester Cap:** The standard arrester cap shown features wide slots for single or through connection lead wires.



**Standard Mounting Brackets**

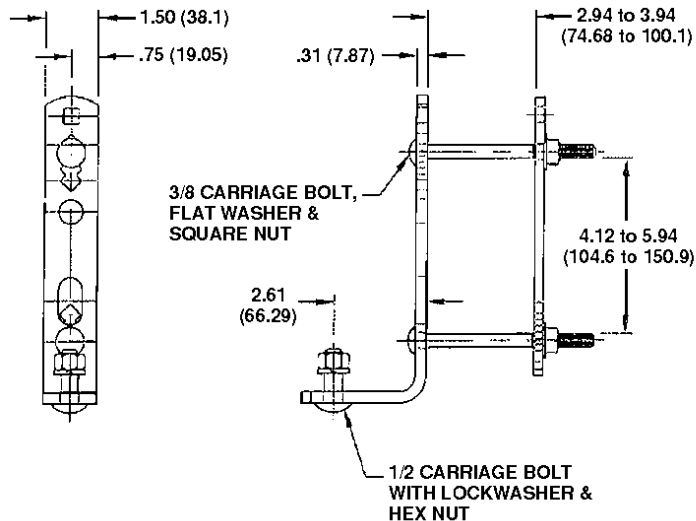

Dimensions: Inches (mm)

**Crossarm Mounting  
Part No. 273456-3001**

**Hardware Options**

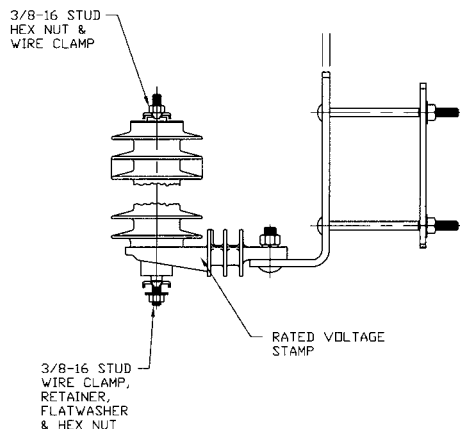

**Hardware Code 7224**

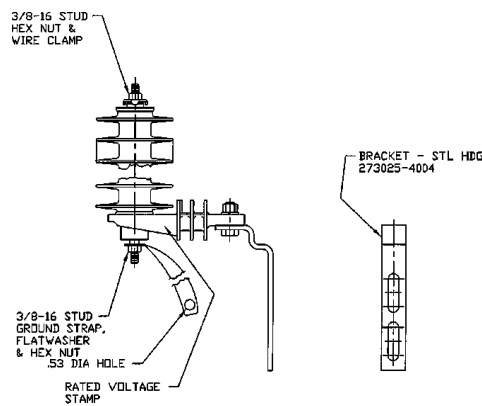

**Hardware Code 7233**

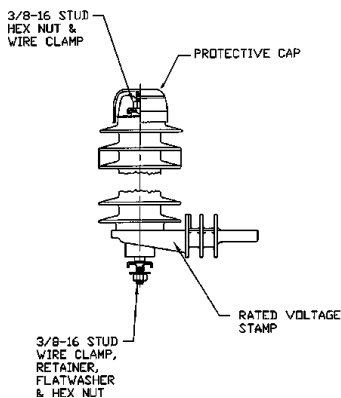

**Hardware Code 7314**