

CAST IRON POLE LINE HARDWARE

Warranty - Material

Hubbell Power Systems, Inc. warrants all products sold by it to be merchantable (as such term is defined in the Uniform Commercial Code) and to be free from defects in material and workmanship. Buyer must notify the Company promptly of any claim under this warranty. The Buyer's exclusive remedy for breach of this warranty shall be the repair or replacement, F.O.B. factory, at the Company's option, of any product defective under the warranty which is returned to the Company within one year from the date of shipment. NO OTHER WARRANTY, WHETHER EXPRESS OR ARISING BY OPERATION OF LAW, COURSE OF DEALING, USAGE OF TRADE OR OTHERWISE IMPLIED, SHALL EXIST IN CONNECTION WITH THE COMPANY'S PRODUCTS OR ANY SALE OR USE THEREOF. The Company shall in no event be liable for any loss of profits or any consequential or special damages incurred by Buyer. The Company's warranty shall run only to the first Buyer of a product from the Company, from the Company's distributor, or from an original equipment manufacturer reselling the Company's product, and is non-assignable and non-transferable and shall be of no force and effect if asserted by any person other than such first Buyer. This warranty applies only to the use of the product as intended by Seller and does not cover any misapplication or misuse of said product.

Warranty - Application

Hubbell Power Systems, Inc. does not warrant the accuracy of and results from product or system performance recommendations resulting from any engineering analysis or study. This applies regardless of whether a charge is made for the recommendation, or if it is provided free of charge.

Responsibility for selection of the proper product or application rests solely with the purchaser. In the event of errors or inaccuracies determined to be caused by Hubbell Power Systems, Inc., its liability will be limited to the re-performance of any such analysis or study.



Minimum order quantities may apply.
Contact factory for test information.

NOTE: Because Hubbell has a policy of continuous product improvement, we reserve the right to change design and specifications without notice.
©Copyright 2006 Hubbell • 210 North Allen Street • Centralia, MO 65240

AUXILIARY EYES

Adds additional guy attachment to existing anchor rod. Also can be used as a pulling eye for guying tension.

Catalog No.	Anchor Rod Diameter	Maximum Strand Size	Thimble Diameter	Approx. Ship Wt. Lbs. Per 100 Pcs.
BB155A	5/8" - 1"	1/2"	1 1/2"	270

Ductile iron per ASTM A-536
Hot dipped galvanized per ASTM A-153; U-Bolts .5" diameter



BOLT EYELETS

Slotted hole design to allow thru-bolt to be inserted from eye side. Not threaded.

Catalog No.	Mounting Bolt Diameter	Maximum Strand Size	Approx. Ship Wt. Lbs. Per 100 Pcs.
† B14A	5/8"	—	100
B14B	3/4"	—	100
B12A	5/8"	5/8"	137
B12B	3/4"	5/8"	137

Ductile iron per ASTM A-536
Hot dipped galvanized per ASTM A-153
Contact factory for round bolt hole design.
† RUS Listed

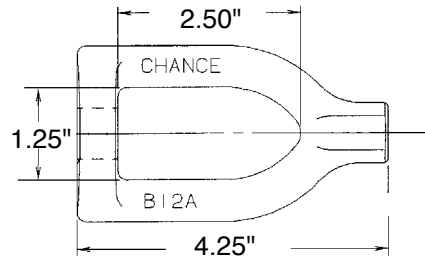
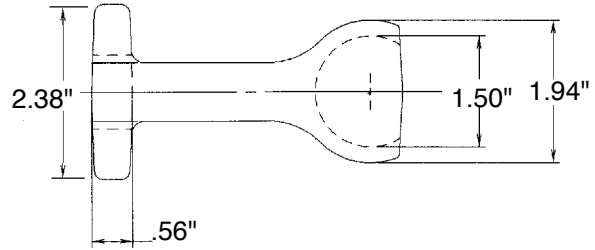

B12

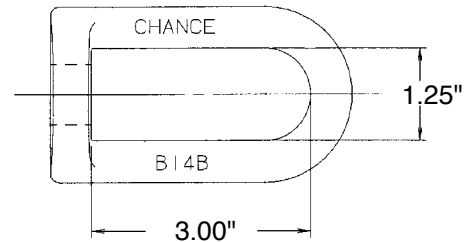
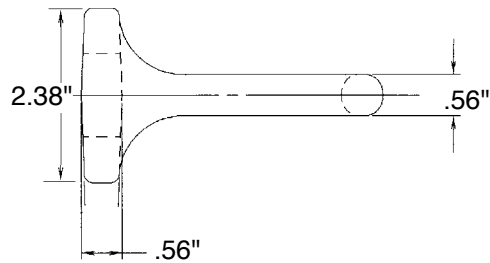

B14

BONDING CLAMPS

Series CB - Bonding clamps are specified for connecting ground wires to guys, messengers, or static wires.

Catalog No.	Cable Range		Approx. Ship Wt. Lbs. Per 100 Pcs.
	Main	Tap	
CB1	9/16" - 1/4" 250 MCM - 4 STR	2 STR - 6 SOL	38

Ductile iron per ASTM A-536
Hot dipped galvanized per ASTM A-153

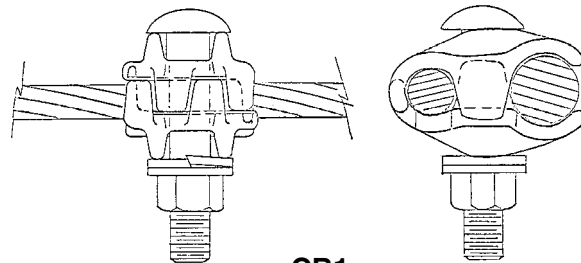

CB1

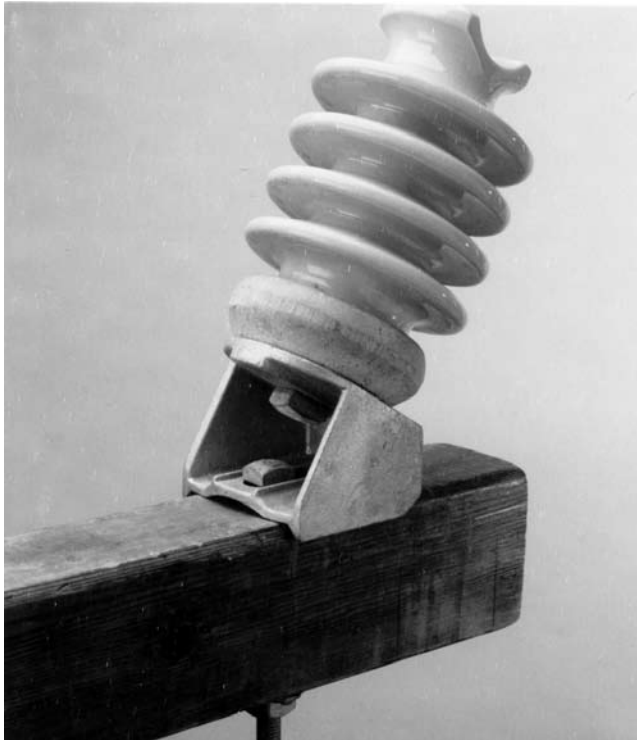

BRACKET, ANGLE CROSSARM

Mounts post insulators at 30° angle on crossarm for use on running corners.

Catalog No.	Crossarm Size	Mtg. Bolt Diameter	Stud Bolt Diameter	Approx. Ship Wt. Lbs. Per 100 Pcs.
1XAB	3 ³ / ₄ " x 4 ³ / ₄ " Max. and Round Crossarms	3/4"	3/4"	610

Ductile iron per ASTM A-536
Hot dipped galvanized per ASTM A-153

BRACKET, CUTOUT AND ARRESTER

Designed to fit NEMA "L" brackets. One bolt mounts bracket to pole.

Catalog No.	"A" Dimensions	Mtg. Bolt Diameter	Equip. Bolt Diameter	Approx. Ship. Wt. Lbs. Per 100 Pcs.
ICB1	7 ⁵ / ₈ "	5/8"	3/8"	147
ICB10	12"	5/8"	3/8"	262

Ductile iron per ASTM A-536
Hot dipped galvanized per ASTM A-153

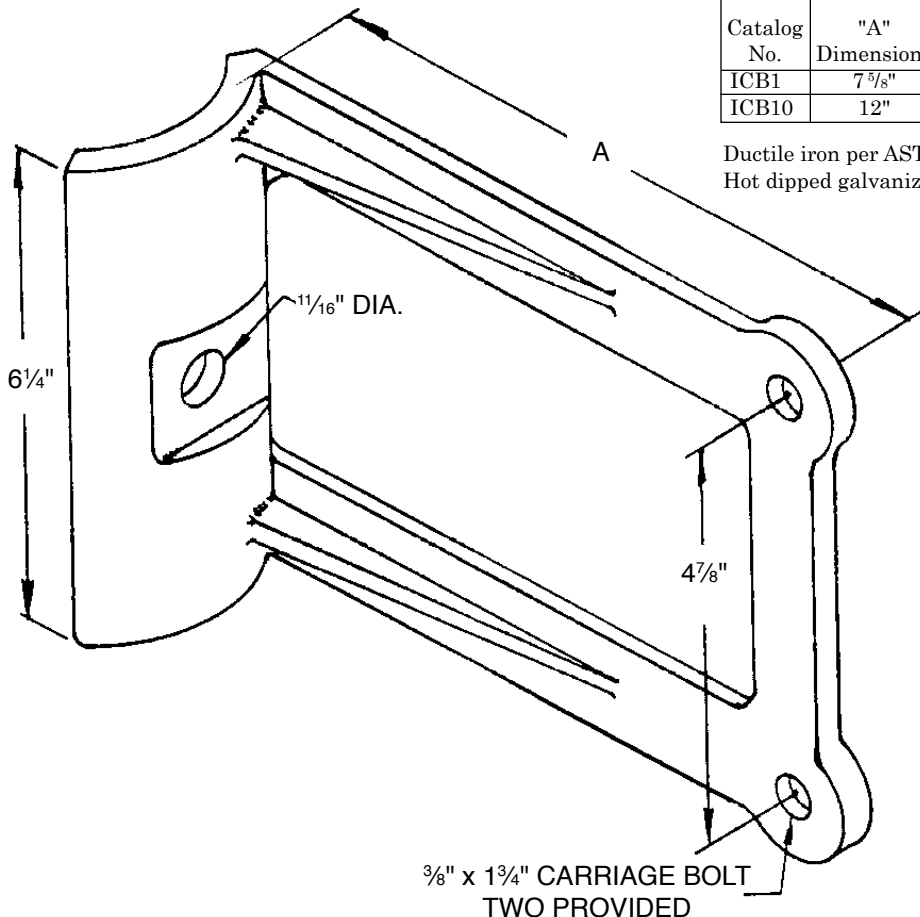

BRACKET, POLE TOP INSULATOR

Mounts post or pin type insulator to top of pole. Variety of bolt hole locations for mounting to pole.

Catalog No.	Mounting Bolt Dia.	Insulator Bolt Dia.	Mtg. Bolt Spacing	Dis. From Insul. Base To Top Hole	Approx. Ship. Wt. Lbs. Per 100 Pcs.
IB2	5/8"	5/8" or 3/4"	4 3/4"	4 3/4"	360
IB3	3/4"	5/8" or 3/4"	5" or 8"	6 3/8"	600
†IB4	5/8"	5/8" or 3/4"	5" or 8"	5"	600

Ductile iron per ASTM A-536
Hot dipped galvanized per ASTM A-153
† RUS Listed

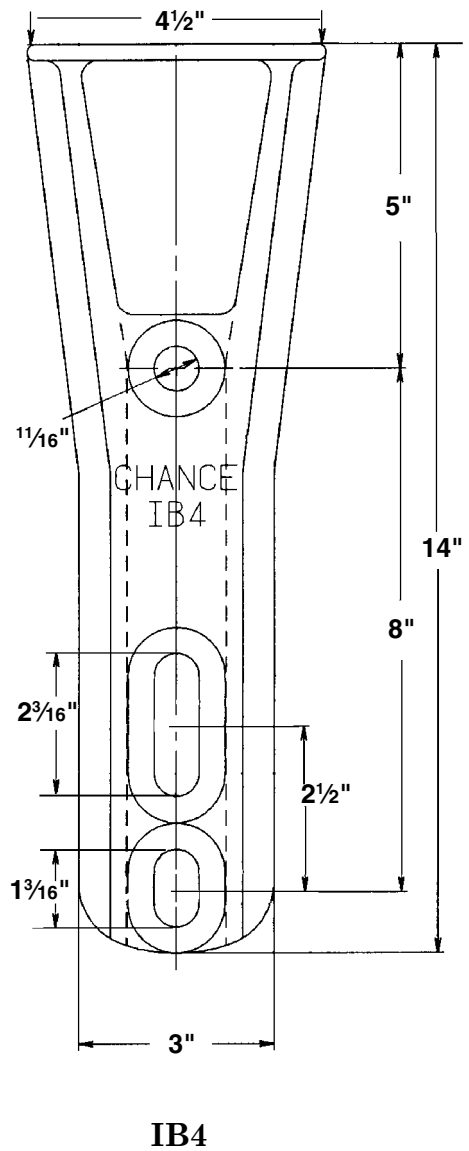
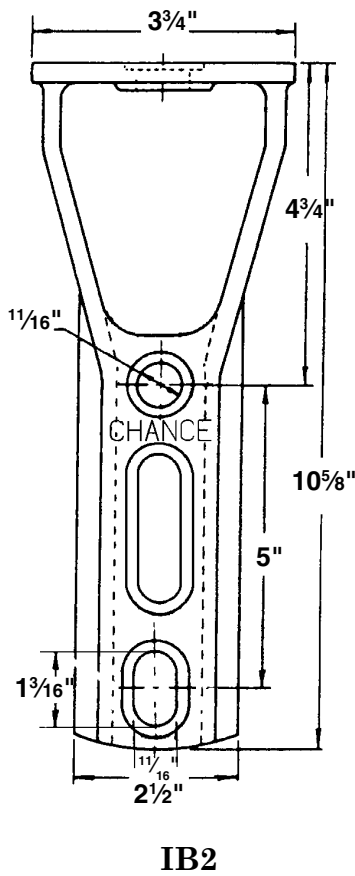
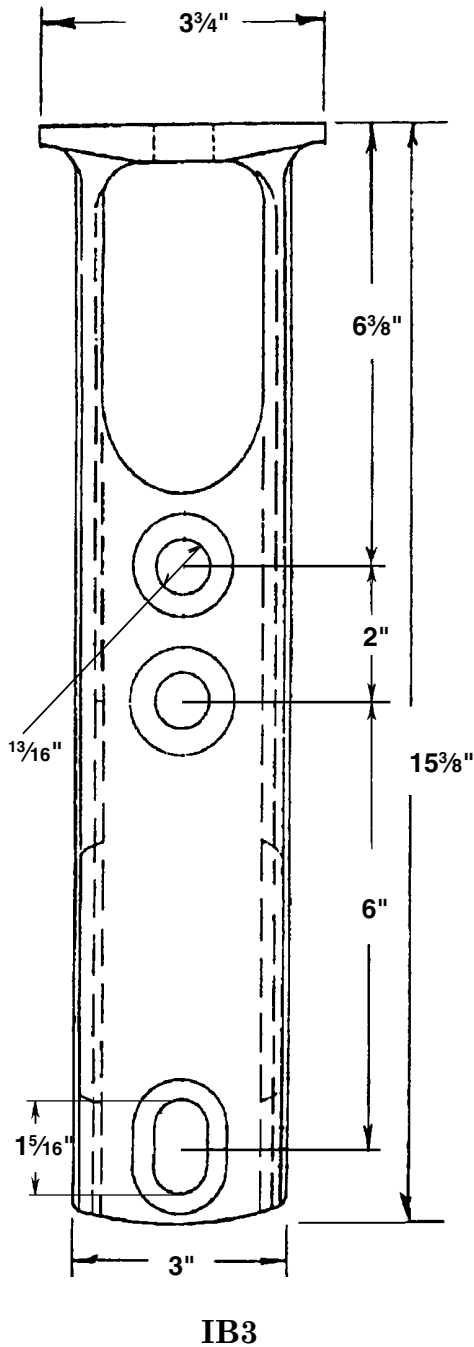

BRACKET, HORIZONTAL INSULATOR

Use for mounting one or two insulator(s) to pole for armless construction.

Catalog No.	Mtg. Bolt Dia.	Max. Insul. Bolt Dia.	Mtg. Bolt Spacing	Insul. Angle Dim.	Space Between Insul. Bases	Approx. Ship. Wt.Lbs. Per 100 Pcs.
1IPTB	Two 5/8"	3/4"	5", 6"	5°	—	333
2IPTB	Two 5/8"	3/4"	4", 5"	—	14"	1025

Ductile iron per ASTM A-536
Hot dipped galvanized per ASTM A-153

1IPTB



2IPTB



BRACKET, VERTICAL INSULATOR

Use for mounting pin or post vertical insulators, cutouts, arresters, or cable terminators. Three-hole style can be used for in-line deadending using suspension insulators.

Catalog No.	Max. Insul. Mtg. Bolt Dia.	Max. Equip. Mtg. Bolt Dia.	Pole Mtg. Bolt Dia.	Pole Mtg. Bolt Spacing	Clearance Pole To Insul. "A"	Approx. Ship. Wt.Lbs. Per 100 Pcs.
LB12A1	3/4"	5/8"	Two 5/8"	5"	12"	860
LB18B1	3/4"	5/8"	Two 5/8"	5"	18"	1300
LB18B3	3/4"	5/8"	Two 5/8"	5"	18"	1400
*T2060594	3/4"	1/2"	Two 5/8"	5"	12"	86
**LB18B3CH	3/4"	5/8"	Two 5/8"	5"	18"	1400

Ductile iron per ASTM A-536
Hot dipped galvanized per ASTM A-153

* T2060594 has 3 captive 1/2" x 2" bolts and nuts included
**LB18B3CH has 2 captive 1/2" x 2" bolts and nuts included with LB18B3.

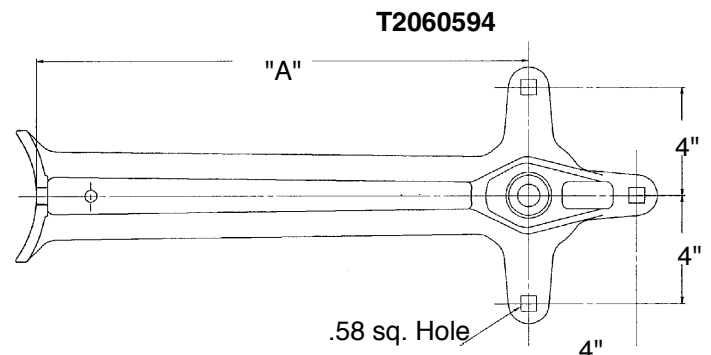
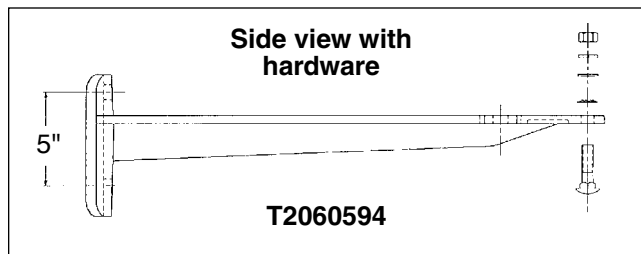
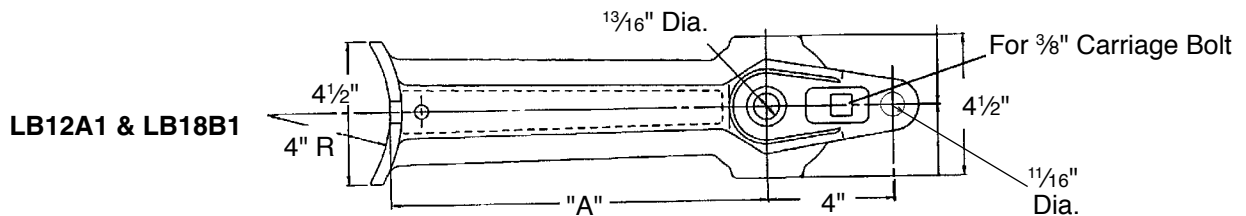
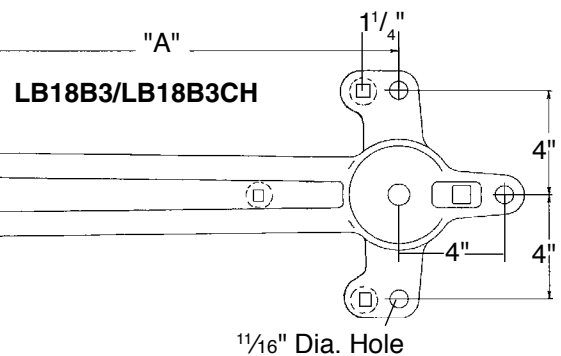



ASC2

CLAMP, AERIAL SUSPENSION

Rigid keeper for maximum clamping action. Bottom groove is curved to prevent damage to messenger. Top hook to support cable during installation.

Catalog No.	Messenger Range	Pole Clearance	Mounting Bolt Dia.	Approx. Ship Wt. Lbs. Per 100 Pcs.
ASC2	.22" - .56"	1 1/2"	5/8"	175
ASC3	.43" - .75"	1 1/2"	5/8"	175

Ductile iron per ASTM A-536
Hot dipped galvanized per ASTM A-153



ASC5

CLAMP, AERIAL SUSPENSION

Heavy duty clamp design uses two bolts to hold messenger to clamp, which prevents clamp slippage if pole shrinks.

Catalog No.	Pole Clear.	Messenger Range	Ground Wire	Mtg. Bolt Dia.	Clamp Bolt Dia.	Approx. Ship Wt. Lbs. Per 100 Pcs.
ASC5	3"	9/16" - 3/4"	6 AWG	5/8"	Two-5/8" Sq. Hd.	725

Ductile iron per ASTM A-536
Hot dipped galvanized per ASTM A-153

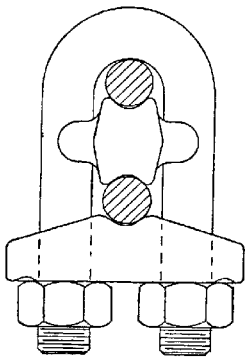

END VIEW

GCU38

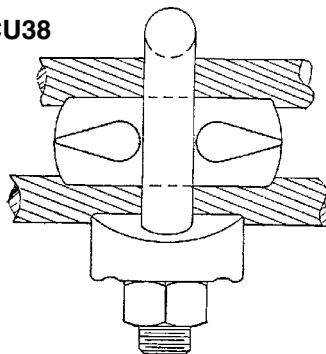

SIDE VIEW

CLAMP, U-BOLT GUY

Can be easily installed without disassembling the clamp. The GCU38C and GCU50C have a spacer block to help prevent damage to strand against U-bolt.

Catalog No.	Strand Size	Type of Nut	U- Bolt Dia.	Approx. Ship Wt. Lbs. Per 100 Pcs.
GCU38	3/16" - 3/8"	HEX	3/8"	80

Clamp Bodies and Spacer: Ductile iron per ASTM A-536
Hot dipped galvanized per ASTM A-153

CLAMP, TWO-BOLT GUY

Bolts installed in opposite directions to allow greater wrench clearance.

Catalog No.	Guy Strand Size	Holding Power lbs.				Clamp Lngth.	Approx. Ship Wt. Lbs. Per 100 Pcs.
		No. Slip	Slip Less Than Dia. of Strand	Slip Less Than 1 1/2"	Two Clamps		
GC131	5/16"	7,300	7,700	9,600	10,700	1 1/8"	66
GC138	3/8"	7,200	9,150	12,150	13,100 Wire Broke	1 3/16"	90

Clamp Bodies: Ductile iron per ASTM A-536
Hot dipped galvanized per ASTM A-153

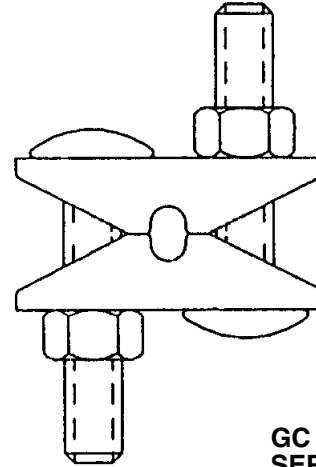

GC SERIES

EXTENSION LINK

The L14 is a one-piece extension link with a clevis pin and cotter key.

Catalog No.	Pin Diameter	L - Inches	Approx. Ship Wt. Lbs. Per 100 Pcs.
L14	5/8"	14	200

Ductile iron per ASTM A-536
Hot dipped galvanized per ASTM A-153

L14

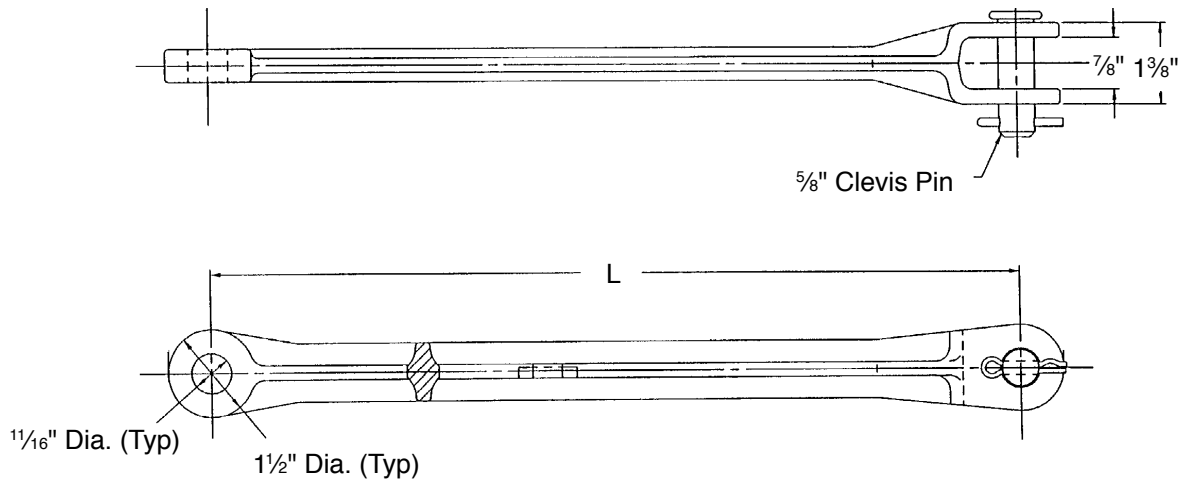

Crossarm Grid Gain

Curved face with spurs prevents need of cutting gain into pole. Slotted hole for easy alignment.

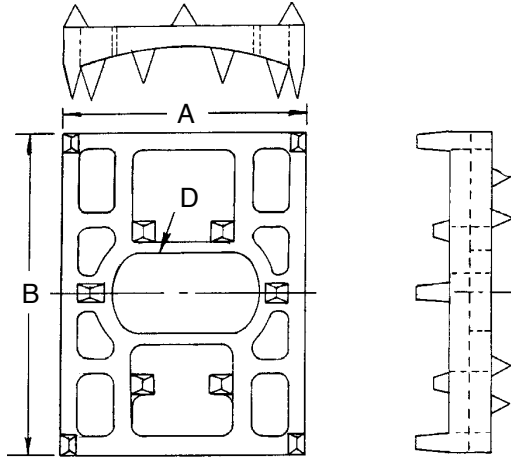

Catalog No.	Dimensions In Inches			Pole Dia. Range	Crossarm Range	Approx. Ship Wt. Lbs. Per 100 Pcs.
	A	B	Max. Bolt Dia. "D"			
PG31	3	4	3/4	6" - 10"	3 1/2" - 5 1/2"	80
PG441	4	4	3/4	6" - 11"	3 1/2" - 5 1/2"	130
PG45	4	5 9/16	3/4	6" - 11"	5" - 7"	180
PG45S	4	5 1/4	3/4	6" - 11"	5" - 7"	180
PG3545	3 1/2	4 1/2	5/8	4" - 9"	4 1/2"	120

Ductile iron per ASTM A-536
Hot dipped galvanized per ASTM A-153

Catalog numbers with "S" suffix have extended bolt hole slot.

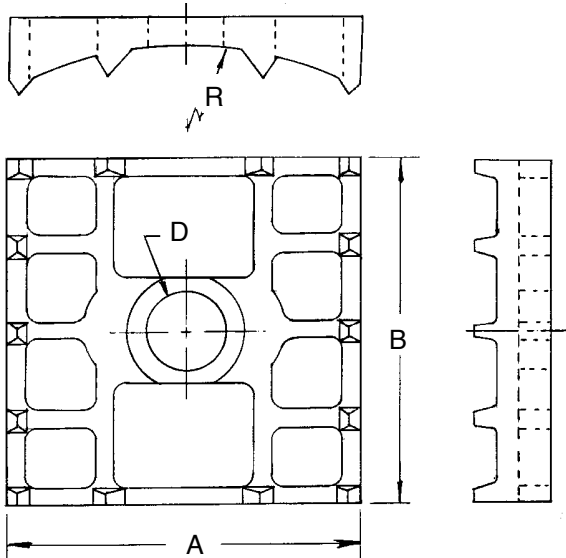

Flat Back Crossarm Gain

Curved face with spurs prevents need of cutting gain into pole. Large surface area reduces crossarm shift.

Catalog No.	Dimensions In Inches			Pole Dia. Range "R"	Approx. Ship Wt. Lbs. Per 100 Pcs.
	A	B	Max. Bolt Dia. "D"		
PG4	4	5 1/2	3/4	6" - 11"	180
PG4A	4	5 1/2	7/8	6" - 11"	175
†PG44	4	4	7/8	6" - 11"	120
PG5	5 3/8	7 1/4	7/8	10" - 16"	375

Ductile iron per ASTM A-536
Hot dipped galvanized per ASTM A-153

† RUS Listed

GAIN, SHELF

Provides strong, stable crossarm connection to the pole. Reduces need for braces. Deadending or guying located directly under arm. Steel crossarm can be mounted to shelf with bolts.

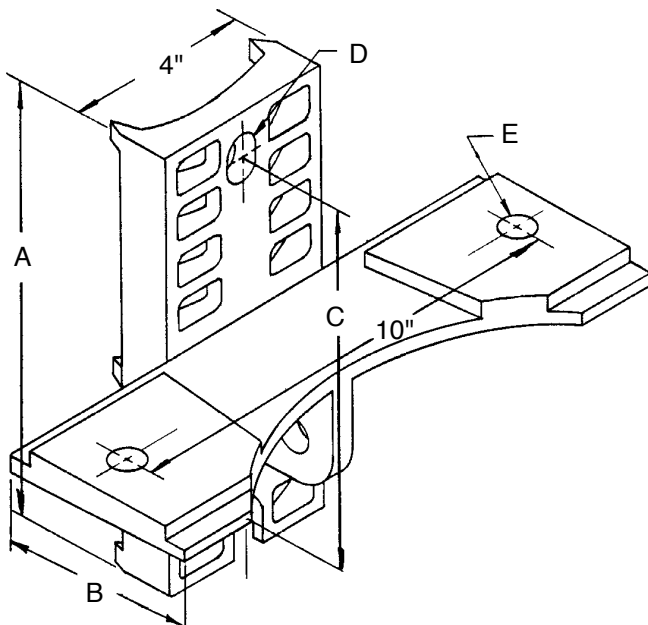

Catalog No.	Dimensions In Inches				Crossarm Range	Mtg. & Bolt "D" No. & Dia.	Approx. Ship Wt. Lbs. Per 100 Pcs.
	A	B	C	E			
PG84XB12	8	3 5/8	6	11/16 Dia. Hole	3 1/2" x 6 1/2"	Two - 5/8"	540
PG84XE12	9 3/4	4 7/16	8	13/16 Dia. Hole	4" Channel	Two - 3/4" Max.	950

Clamp Bodies: Ductile iron per ASTM A-536
Hot dipped galvanized per ASTM A-153

GUY HOOK

Use in down or span guy applications. Spurs resist down slotting. The overturning action is resisted by the wide lower curved heal pad. Contact Factory about Guy Hooks for use on concrete and steel poles.

Catalog No.	Thru-Bolt Dia.	Max. Guy Strand Dia.	Lag Screw Dia.	Approx. Ship Wt. Lbs. Per 100 Pcs.
GH151A	5/8"	7/16"	None	62
† GH5	5/8"	7/16"	1/2"	88
GH5ILS	5/8"	7/16"	None	98
GH6	3/4"	1/2"	1/2"	88
GH6ILS	3/4"	1/2"	None	98
GH6X	7/8"	5/8"	1/2" or 3/4"	240
GH6XBILS	1"	5/8"	None	225

Suffix "ILS" indicates cast in integral lag
 Ductile iron per ASTM A-536
 Hot dipped galvanized per ASTM A-153
 † RUS Listed

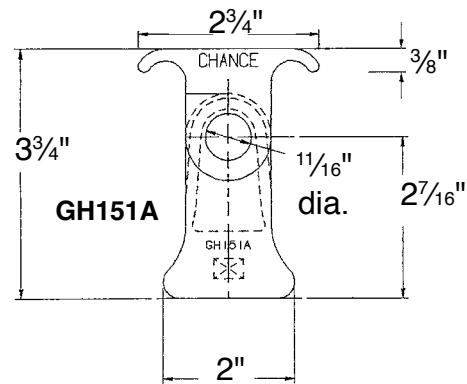
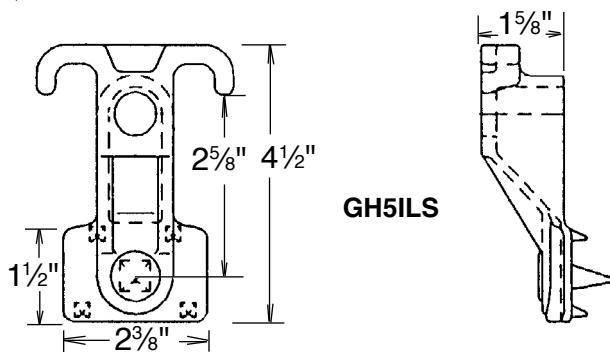
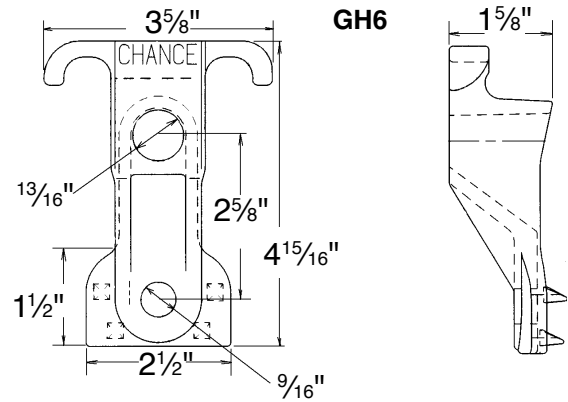

GUY HOOK, SPAN TYPE

For guy attachment, use at angles 0° to 30° from horizontal.

Catalog No.	Max. Thru-Bolt Dia.	Max. Guy Strand Dia.	Approx. Ship Wt. Lbs. Per 100 Pcs.
GH2	5/8"	1/2"	66
GH3	3/4"	1/2"	64

Ductile iron per ASTM A-536
 Hot dipped galvanized per ASTM A-153



PIN, ANGLE

The crossarm corner pin is made of ductile iron, hot dip galvanized. Made with 1" lead threads for 1" thread insulators at an angle 60° from horizontal. Attached to the crossarm by means of a square head bolt, which is furnished as part of the pin.

Catalog No.	Crossarm Size	Pin Height Above Arm	Bolt Size	Thread Size	Approx. Ship Wt. Lbs. Per 100 Pcs.
PS8779	4"	5"	5/8" x 7"	1"	315
PBA841	4"	8 1/4"	5/8" x 7"	1"	541

Ductile iron per ASTM A-536
 Hot dipped galvanized per ASTM A-153

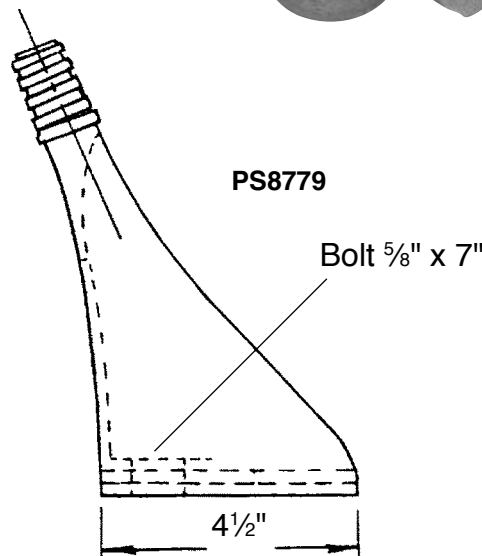

GEP5

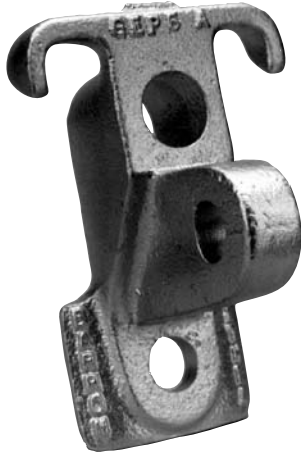

GEP5: 1¹/₁₆" Dia.
 GEP5A: 1³/₁₆" Dia.

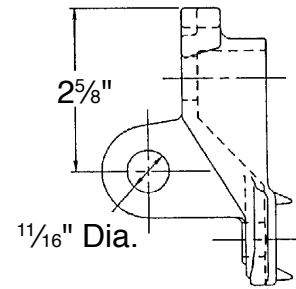
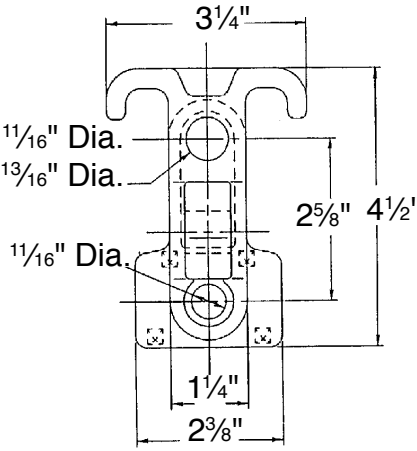

PLATE, POLE EYE

Allows guy loop to be made up on the ground as well as providing a clevis eye plate capability. Spurs prevent slippage down the pole. Contact Factory about eye plates for use on concrete and steel poles.

Catalog No.	Mounting Bolt Dia.	Max. Pin Diameter	Max. Strand Size	Approx. Ship Wt. Lbs. Per 100 Pcs.
GEP5	5/8"	5/8"	5/8"	175
GEP5A	3/4"	5/8"	5/8"	175

Ductile iron per ASTM A-536
 Hot dipped galvanized per ASTM A-153

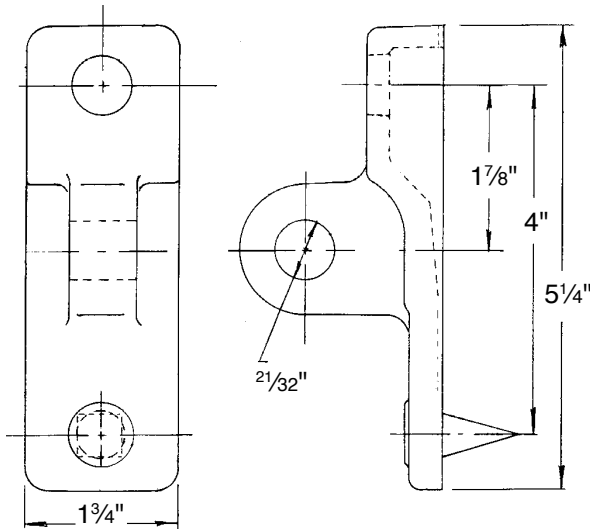

PLATE, POLE EYE

Narrow profile eye plate provides clevis eye with 5/8" maximum pin diameter.

Catalog No.	Mounting Bolt Diameter	Lag Screw Diameter	Max. Pin Diameter	Approx. Ship Wt. Lbs. Per 100 Pcs.
GEP5C	5/8"	1/2"	5/8"	155
GEP5D	3/4"	Integral Spur	5/8"	155
GEP5E	3/4"	1/2"	5/8"	155
GEP5G	3/4"	3/4"	5/8"	155

Ductile iron per ASTM A-536
 Hot dipped galvanized per ASTM A-153

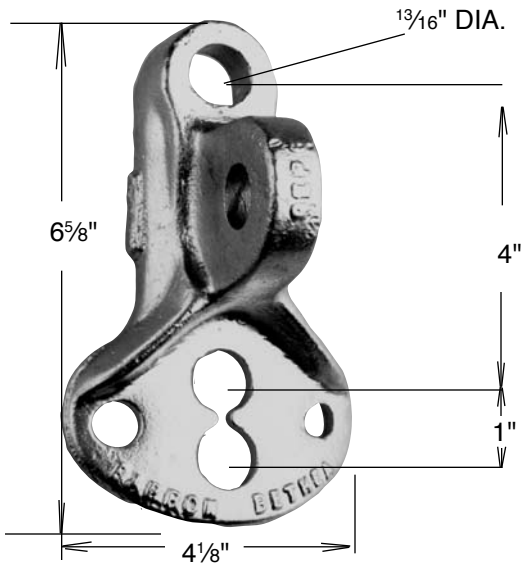

PLATE, POLE EYE

GEP6 style eye plate provides large pad area to spread forces over pole surface. Ideal for guy strain insulator installation.

Catalog No.	Mounting Bolt Diameter	Maximum Pin Diameter	Approx. Ship Wt. Lbs. Per 100 Pcs.
GEP6	3/4"	3/4"	269

Ductile iron per ASTM A-536
 Hot dipped galvanized per ASTM A-153

PLATE, POLE EYE

Top curved groove has $\frac{3}{8}$ " radius to allow guy attachment. Groove captures guy attachment against pole to help prevent possibility of guy slipping off hook. Also has pole eye lug.

Catalog No.	Max. Pin Dia.	"A" Mtg. Bolts No. & Dia.	Approx. Ship Wt. Lbs. Per 100 Pcs.
GEP7	$\frac{7}{8}$ "	Two 1"	559
GEP7A	$\frac{7}{8}$ "	Two $\frac{7}{8}$ "	564
GEP12	$\frac{3}{4}$ "	One $\frac{7}{8}$ "	332

Ductile iron per ASTM A-536
Hot dipped galvanized per ASTM A-153

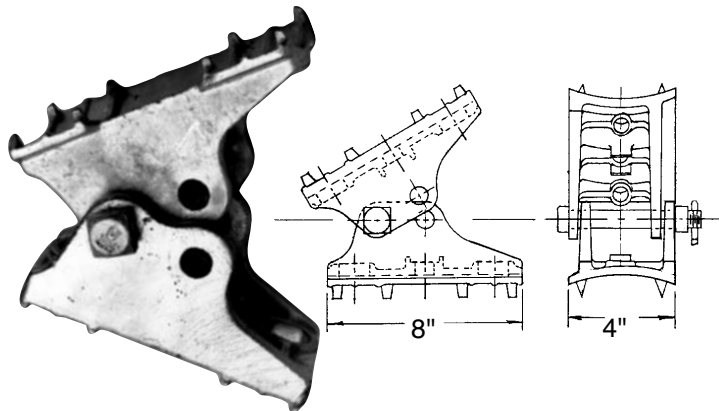
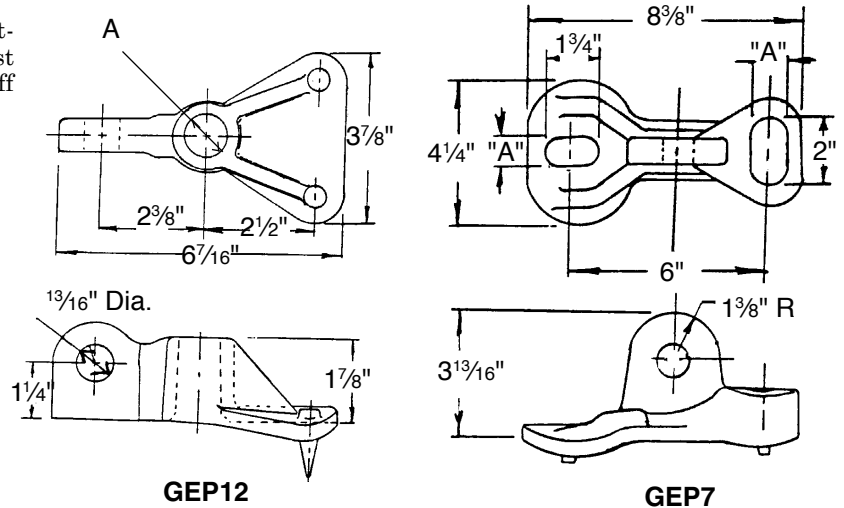

POLE BRACE

For use in push pole application where guying is not feasible. Brace adjusts for different pole angles.

Catalog No.	Pole Diameter	Base Diameter	Mounting Bolt Dia.	Hinge Bolt Dia.	Approx. Ship Wt. Lbs. Per 100 Pcs.
SG611	6" - 11"	4" x 8"	$\frac{3}{4}$ "	$\frac{3}{4}$ "	750

Ductile iron per ASTM A-536
Hot dipped galvanized per ASTM A-153

THIMBLE CLEVIS, GUY WIRE

Commonly used for attaching guy to pole eye plate. Clevis pin has humped cotter key.

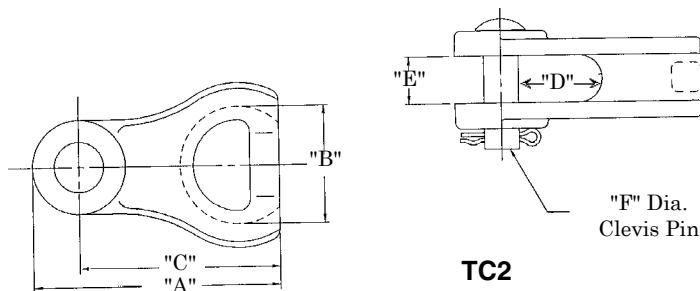

Catalog No.	Dimensions In Inches						Approx. Ship Wt. Lbs. Per 100 Pcs.
	A	B	C	D	E	F	
TC1	$4\frac{9}{16}$	$1\frac{3}{4}$	$3\frac{3}{4}$	$1\frac{7}{16}$	$\frac{3}{4}$	$\frac{5}{8}$	100
TC2	$5\frac{5}{16}$	$2\frac{1}{2}$	$4\frac{5}{16}$	$1\frac{3}{4}$	1	$\frac{3}{4}$	275

Ductile iron per ASTM A-536
Hot dipped galvanized per ASTM A-153

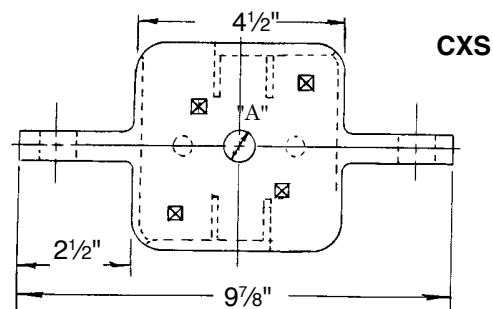
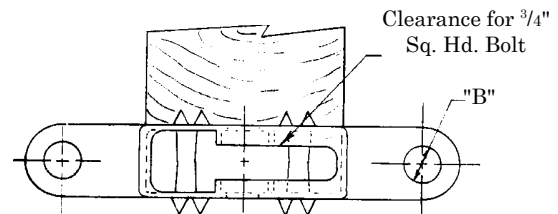

TWIN ARM SPACER

Connects two crossarms in twin arm application. Lugs provide for deadending attachment.

Catalog No.	Mtg. Bolt Hole "A"	Clevis Bolt Hole "B"	For Cross-Arm Sizes	Approx. Ship Wt. Lbs. Per 100 Pcs.
CXS1	$\frac{11}{16}$ "	$\frac{11}{16}$ "	$3\frac{1}{4}$ " x $4\frac{1}{4}$ " & 4 " x 5 "	440

Ductile iron per ASTM A-536
Hot dipped galvanized per ASTM A-153

WASHERS, CAST

Cast washers provide excellent strength characteristics. Reinforcing ribs helps prevent washer from crushing.

CURVED SQUARE

Size Inches	Catalog No.	Max. Bolt Dia. Inches	Thickness At Boss Inches	Approx. Ship Wt. Lbs. Per 100 Pcs.
*2 ¹ / ₄ x 2 ¹ / ₄	GCW1	⁵ / ₈	¹ / ₄	20
*3 x 3	†GCW31	⁵ / ₈	³ / ₈	45
*3 x 3	GCW31A	³ / ₄	³ / ₈	45
*4 x 4	†GCW41	³ / ₄	¹ / ₂	100
4 x 4	GCW41A	⁷ / ₈	¹⁷ / ₃₂	100

† RUS Listed

* NEMA Standard

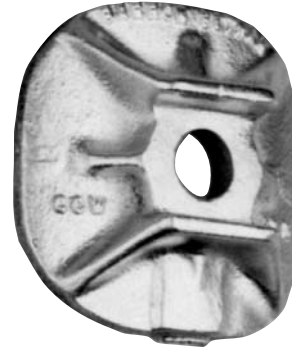

GCW

CURVED RECTANGULAR

Size Inches	Catalog No.	Max. Bolt Dia. Inches	Thickness At Boss Inches	Approx. Ship Wt. Lbs. Per 100 Pcs.
*2 ¹ / ₄ x 3 ¹ / ₂	CRW3	³ / ₄	³ / ₈	45
*3 x 4	†CRW4A	⁷ / ₈	¹ / ₂	93
3 x 4	CRW4B	1	¹ / ₂	93

† RUS Listed

* NEMA Standard



GCW31

ROUND FLAT

Size Inches	Catalog No.	Max. Bolt Dia. Inches	Thickness At Boss Inches	Approx. Ship Wt. Lbs. Per 100 Pcs.
*3 Dia.	GWR3	³ / ₄	⁷ / ₁₆	44
*4 Dia.	GWR4	⁷ / ₈	¹ / ₂	87
4 Dia.	GWR4A	1	¹ / ₂	87

* NEMA Standard



GWR

SQUARE FLAT

Size Inches	Catalog No.	Max. Bolt Dia. Inches	Thickness At Boss Inches	Approx. Ship Wt. Lbs. Per 100 Pcs.
*2 ¹ / ₄ x 2 ¹ / ₄	†BB214	⁵ / ₈	⁹ / ₃₂	20
*2 ¹ / ₄ x 2 ¹ / ₄	BB214A	³ / ₄	⁹ / ₃₂	20

† RUS Listed

* NEMA Standard

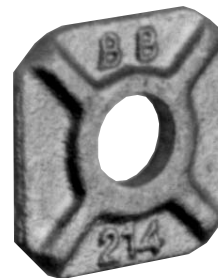

BB