



OHIO BRASS

| TEXT | NOTES |
|--|-------|
| <p style="text-align: center;"><u>DynaVar Arrester Application</u></p> <p><u>General</u></p> <p>A surge arrester is the most common example of a device used to protect high-voltage substation equipment from harmful overvoltage surges. The general subject of surge protection for station insulation involves application considerations for not only protective devices such as surge arresters and gaps but also shielding and grounding systems and equipment insulation levels. The objective for surge protection of a power system is to achieve, at minimum cost, an acceptably low level of service interruptions and an acceptably low level of transformer failures due to surge-related events.</p> <p>Surge arrester selection and application will be considered in the following sections. Discussions will be further limited to DynaVar zinc-oxide arresters to provide application guidelines for this arrester technology.</p> <p><u>DynaVar Arresters</u></p> <p>While Ohio Brass Dynagap arresters used silicon-carbide elements, DynaVar arresters utilize zinc-oxide valve elements. Figure 1 illustrates the extreme improvement in nonlinearity achieved by zinc-oxide valve elements as compared to silicon-carbide valve elements.</p> <p>The vastly improved valve element characteristics of DynaVar arresters are utilized in the operation of the arresters. The valve elements carry all or a substantial portion of the arrester's normal operating voltage. The task of limiting follow current is borne entirely by the valve elements, which will allow currents only in the milliamperage range at normal system voltage. Gaps, used with VS and VX designs, are of a heavy-duty horn gap design. They insert a linear impedance in series with the valve elements. This assists in limiting increases in arrester heat generation at elevated temperatures to insure thermal stability. The origin of this concern is the negative temperature coefficient of resistive current for the zinc-oxide valve elements in the range of normal system voltages.</p> <p>Section views for typical DynaVars (Figure 2) show the different unit types which cover the range of system voltages thru 765 kV. VI and VIA intermediate arresters use 48-mm diameter valve elements and are available for system voltages from 2.4 kV to 138 kV. VL and VLA arresters are applied on systems below 69 kV and use 60-mm diameter valve elements. VN and VS arresters cover the range of system voltages from 69 kV thru 400 kV and utilize 75-mm diameter valve elements. VX arresters apply for system voltages 500 kV and above and utilize two parallel stacks of 75-mm discs. They may also be appropriate for lower voltage, high energy applications, such as on underground cable systems.</p> <p><u>Selection of Arrester Size</u></p> <p>The most critical function of any surge arrester is the protection of the insulation of other apparatus such as transformers from damaging overvoltages. To this end, it is usually desirable to select the minimum-sized arrester that will perform this task while not self-destructing under any reasonably possible series of events at the particular system location.</p> <p>The two types of overvoltages usually considered with respect to arrester survival for silicon-carbide arresters were</p> | |

OHIO BRASS

| TEXT | NOTES |
|---|-------|
| <p>60-Hz temporary overvoltages (neutral shifts due to faults) and transient overvoltages (line switching). Other factors such as load rejection, long unloaded transmission lines, and resonant conditions were important in determining arrester size, but to a lesser degree.</p> <p>Because the zinc-oxide valve blocks in MOV arresters carry all or a substantial portion of total arrester continuous operating voltage, the most important criterion for selection of the minimum arrester size is the continuous operating voltage. All MOV arresters have, therefore, been assigned a maximum continuous operating voltage (MCOV) by their manufacturers. The definition in ANSI/IEEE is: "The maximum designated root-mean-square (rms) value of power frequency voltage that may be applied continuously between the terminals of the arrester."</p> <p>This standard assigns two ratings to an arrester; the MCOV rating and the duty-cycle voltage rating. Therefore, when identifying an arrester size by rating -- use MCOV rating or duty-cycle voltage rating to avoid confusion (E.g., The 180 kV duty-cycle voltage rating has 144 kV MCOV. The 180 kV MCOV rating has a 228 kV duty-cycle voltage rating.).</p> <p><u>MCOV and Conventional Rating</u></p> <p>Silicon-carbide arrester designs were rated by the voltage at which they could pass the ANSI duty-cycle test. Selection of a silicon-carbide arrester was made with a rating equal to or greater than the maximum line-to-line system operating voltage times the coefficient of grounding at the point of arrester application (Figure 3). This is affirmed by C62.2-1987, section 3, which states, "It is recommended that an arrester voltage rating at least 25 percent higher than the maximum operating phase-to-ground voltage be selected for stations when possible."</p> <p>For an effectively grounded system (coefficient of grounding less than or equal to 0.80), a DynaVar arrester with MCOV equal to maximum normal line-to-neutral voltage is suitable. Thus, for effectively grounded systems where arrester size will not be dictated by other factors, DynaVar MCOV is selected by dividing maximum system line-to-line rms voltage by $\sqrt{3}$. (Consideration of extremely severe switching surges and other factors will be covered later.)</p> <p>A 138-kV system typically has a maximum line-to-line voltage of 145-kV rms. Dividing by $\sqrt{3}$ gives the maximum normal line-to-ground voltage of 84 kV rms. The appropriate size arrester is the DynaVar with 84-kV MCOV.</p> <p>That DynaVar VS and VX arresters can be selected in this manner for effectively grounded systems is illustrated in Figure 4. For an effectively grounded system, the maximum voltage on an unfaulted phase will be $0.8 \times \sqrt{3} \times \text{MCOV}$ or 1.4 times MCOV. The minimum 60-Hz sparkover versus arrester (ZnO disc) temperature shows that VS (42-245 kV MCOV) and VX (318-485 kV MCOV) arresters would not normally operate under this condition, even with high ambient temperatures.</p> <p>Gapless VN, VL and VI arresters have a temporary over-voltage capability of 40 percent for more than one second, which is sufficient for circuit breakers to respond to a fault on grounded neutral circuits, as shown in Figure 5.</p> <p>Figures 6 and 7 list the normally recommended DynaVar arrester sizes for various system voltages and grounding practices. Arresters listed under grounded neutral circuits assume that the system is effectively grounded and arrester MCOV is maximum line-to-line voltage divided by $\sqrt{3}$.</p> <p>Alternate arresters are listed for ungrounded systems. Station DynaVars listed under normal duty (1) on Figure 6 have an MCOV of at least maximum line-to-line voltage divided by 1.4. DynaVars listed under severe duty (2) have an MCOV of at least</p> | |



OHIO BRASS

| TEXT | NOTES | | | | | | | | |
|---|------------------------------------|------------------------------------|------------------------------------|------------------------------|--|---------------------------|--------------------------------------|---------------------------------|--|
| <p>maximum line-to-line voltage divided by 1.25. The latter sizes are recommended where high ambient temperature and maximum energy discharge could occur prior to the extended system ground fault.</p> <p>On Figure 7, gapless DynaVars listed under ungrounded systems, normal duty (1) have an MCOV of at least maximum line-to-line voltage divided by 1.25. DynaVars on Figure 7 listed under severe duty (2) have an MCOV of at least maximum line-to-line voltage divided by 1.11. This means that on some ungrounded systems, a larger gapless arrester is needed than with a gapped design. Notice that at 115 kV ungrounded, the gapless design can be 98 kV MCOV. Yet, for 115 kV grounded systems, both gapped and gapless designs can be 70 kV MCOV.</p> <p><u>Insulation Coordination</u></p> <p>The methods used to insure insulation coordination with DynaVar arresters differ from those for silicon-carbide MPR arresters only in the way DynaVar protective levels are defined. For a review of silicon-carbide arrester insulation coordination, a voltage-time curve for MPR arrester coordination with a typical oil-filled transformer is shown in Figure 8.</p> <p>Transformer withstand voltages are plotted from the following points obtained from the manufacturer or standards: (1) front-of-wave withstand; (2) chopped-wave withstand at about 3 μs; (3) full-wave withstand from 8 to 30 μs; and (4) switching-surge withstand from about 50 μs and longer. MPR arrester protective levels are given as follows:</p> <ol style="list-style-type: none"> I. Sparkover per ANSI C62.1 <ol style="list-style-type: none"> a) Maximum front-of-wave -- 100 kV/μs per 12 kV of arrester rating to 2000 kV/μs. b) 1.2 x 50 μs. c) Maximum switching surge -- fronts from 30 to 2000 μs. II. Discharge Voltages per ANSI C62.1 <p>8x20 μs current waves with peak amplitudes from 1.5 kA through 40 kA.</p> <p>Coordination between MPR arrester and transformer insulation is checked by comparing the following points of transformer withstand voltage and arrester protective level.</p> <table border="0" style="width: 100%; border-collapse: collapse;"> <thead> <tr> <th style="text-align: left; border-bottom: 1px solid black; width: 40%;"><u>MPR Protective Level</u></th> <th style="text-align: left; border-bottom: 1px solid black; width: 60%;"><u>Transformer Withstand Level</u></th> </tr> </thead> <tbody> <tr> <td>1. Maximum front-of-wave sparkover</td> <td>Chopped-wave withstand (CWW)</td> </tr> <tr> <td>2. Maximum 1.2 x 50 μs sparkover and 8 x 20 μs discharge voltage</td> <td>Full-wave withstand (BIL)</td> </tr> <tr> <td>3. Maximum switching surge sparkover</td> <td>Switching surge withstand (BSL)</td> </tr> </tbody> </table> <p>At each of the above three points on the transformer withstand curve, a protective margin is calculated as:</p> $\% M = \left(\frac{\text{Transformer Withstand}}{\text{Protective Level}} - 1 \right) \times 100$ <p>The usually accepted minimum margins are 20 percent for chopped-wave withstand and full-wave withstand and 15 percent for</p> | <u>MPR Protective Level</u> | <u>Transformer Withstand Level</u> | 1. Maximum front-of-wave sparkover | Chopped-wave withstand (CWW) | 2. Maximum 1.2 x 50 μ s sparkover and 8 x 20 μ s discharge voltage | Full-wave withstand (BIL) | 3. Maximum switching surge sparkover | Switching surge withstand (BSL) | |
| <u>MPR Protective Level</u> | <u>Transformer Withstand Level</u> | | | | | | | | |
| 1. Maximum front-of-wave sparkover | Chopped-wave withstand (CWW) | | | | | | | | |
| 2. Maximum 1.2 x 50 μ s sparkover and 8 x 20 μ s discharge voltage | Full-wave withstand (BIL) | | | | | | | | |
| 3. Maximum switching surge sparkover | Switching surge withstand (BSL) | | | | | | | | |

OHIO BRASS

| TEXT | NOTES | | | | | | | | |
|--|---------------------------------|-----------------------------|---|------------------------------|--|---------------------------|--|---------------------------------|--|
| <p>switching surges. For coordination of the 8 x 20-μs current-wave discharge voltage with full-wave transformer withstand voltage, a value of coordination current must be selected. For effectively shielded installations, a conservative approximation for the maximum discharge current is suggested in C62.2 by the formula:</p> $i_a = (2 e_o - e_a) / Z$ <p>where i_a = surge current in amperes e_o = 1.2 x line insulation level in volts (1.2 x 50-μs critical flashover) Z = line surge impedance in ohms e_a = arrester discharge voltage in volts</p> <p>DynaVar VS protective levels (discharge voltage characteristics) are plotted with the oil-filled transformer withstand voltage characteristics (Figure 9).</p> <p>Transformer withstand voltages are plotted as before. DynaVar protective levels are given as crest kV versus current magnitude and time to discharge voltage crest. Time to crest of the voltage waves as shown is about 0.7 x the time to actual crest of the corresponding current waves. The standard 8 x 20-μs ANSI (10 μs to actual crest) discharge voltages are obtained at 7 μs.</p> <p>In order to coordinate with the transformer withstand characteristics, the following points from the DynaVar protective level curves are listed in the catalog and application guide:</p> <ol style="list-style-type: none"> 1. Maximum switching surge protective level -- The fast switching surge (45 x 90 μs) discharge voltage defines the DynaVar switching surge protective level. Published DynaVar protective levels are based upon discharge currents of 500 A, 1000 A or 2000 A depending upon the system voltage at which the arrester will be used. (150 kV and below 500 A, 151-325 kV 1000 A, 326-900 kV 2000 A) these are the "switching surge classifying current". 2. Maximum 8 x 20-μs discharge voltage -- The discharge voltages resulting when ANSI 8 x 20-μs current impulses are discharged through the arrester are listed from 1.5 kA through 40 kA. A specific coordination current is selected as before, based primarily on line insulation and surge impedance. 3. Maximum 0.5-μs discharge voltage -- The discharge voltage for an impulse current wave which produces a voltage wave cresting in 0.5 μs is listed in place of the front-of-wave sparkover point. The discharge currents used for station class arresters are 10 kA for arrester MCOV from 2.6 through 245 kV, 15 kA for 318 through 335 kV MCOV, and 20 kA for 470 kV MCOV, corresponding to 10,000 A for system voltages below 550 kV, 15,000 A for 550 kV, and 20,000 A for 800 kV systems. The "Lightning Impulse Coordinating Current" for all intermediate class arresters is 500 A. <p>The coordination points for DynaVar arresters are summarized in the following table:</p> <table border="1"> <thead> <tr> <th>DynaVar Protective Level</th> <th>Transformer Withstand Level</th> </tr> </thead> <tbody> <tr> <td>1. Maximum 0.5-μs discharge voltage</td> <td>Chopped-wave withstand (CWW)</td> </tr> <tr> <td>2. Maximum 8 x 20-μs current discharge voltage</td> <td>Full-wave withstand (BIL)</td> </tr> <tr> <td>3. Maximum switching surge 45 x 90 μs discharge voltage</td> <td>Switching surge withstand (BSL)</td> </tr> </tbody> </table> <p>Specific examples of insulation coordination with DynaVar arresters and comparison of margins with equivalently sized MPR arresters will be covered in a later section. It will</p> | DynaVar Protective Level | Transformer Withstand Level | 1. Maximum 0.5- μ s discharge voltage | Chopped-wave withstand (CWW) | 2. Maximum 8 x 20- μ s current discharge voltage | Full-wave withstand (BIL) | 3. Maximum switching surge 45 x 90 μ s discharge voltage | Switching surge withstand (BSL) | |
| DynaVar Protective Level | Transformer Withstand Level | | | | | | | | |
| 1. Maximum 0.5- μ s discharge voltage | Chopped-wave withstand (CWW) | | | | | | | | |
| 2. Maximum 8 x 20- μ s current discharge voltage | Full-wave withstand (BIL) | | | | | | | | |
| 3. Maximum switching surge 45 x 90 μ s discharge voltage | Switching surge withstand (BSL) | | | | | | | | |



OHIO BRASS

| TEXT | NOTES | | | | | | | | | | |
|--|---|---|-------------------------|------------------------------|---------------------|-------------------------------|-------------------|-------------------------------|----------------|--------------------------------|--|
| <p>examine the following general statements in more detail. For equivalently sized arresters -- DynaVar MCOV equal to MPR rating times 0.81 -- increased protective margins will be realized for both 0.5 μs and switching surge discharge voltage protective levels. Smaller-sized DynaVars will be applicable in many instances, resulting in further improvements in protective margins at a fixed BIL.</p> <p><u>Transmission Line Switching Surge Durability</u></p> <p>Because the noncurrent-limiting DynaVar gaps do not develop significant arc voltage, the arrester current, discharge voltage and, therefore, arrester energy for all DynaVar designs are determined by the zinc-oxide disc characteristics. Thus, for any switching surge, the arrester durability can be expressed in terms of dissipated energy in kilojoules per kV of MCOV.</p> <p>Energy capabilities of DynaVar arresters in terms of kilojoules per kV of MCOV are as follows:</p> <table border="1"> <thead> <tr> <th><u>Arrester MCOV (kV)</u></th> <th><u>Maximum Energy Discharge Capability (kJ/kV MCOV)</u></th> </tr> </thead> <tbody> <tr> <td>2.55 - 98 (VI, VIA, VR)</td> <td>3.4 (Currents 650 A or less)</td> </tr> <tr> <td>2.55 - 39 (VL, VLA)</td> <td>4.9 (Currents 1.0 kA or less)</td> </tr> <tr> <td>42 - 245 (VS, VN)</td> <td>8.9 (Currents 1.5 kA or less)</td> </tr> <tr> <td>318 - 485 (VX)</td> <td>16.2 (Currents 2.7 kA or less)</td> </tr> </tbody> </table> <p>These numbers are the maximum energy discharge capability within a one-minute period. Additional duty is permissible after one minute when disc temperature gradients vanish. Maximum energy discharges can be repeated many times as long as arrester temperatures remain reasonable. Maximum allowable station arrester temperatures for VS and VX can be determined from the previous Figure 4, showing the effect of disc temperature upon arrester 60-Hz sparkover.</p> <p>Accurate determination of arrester discharge energy requires modeling of the arrester and system components in a TNA study. Arrester energy duties obtained in TNA studies can be compared with DynaVar maximum capabilities in the event that arrester type and/or size may be determined by a severe energy discharge requirement. Arrester temperature rises can be calculated from the energy content of a discharge when desired. The VL arrester temperature will increase 11°C for each kJ/kV MCOV of energy discharged. The VS arrester temperature will increase 8.3°C for each kJ/kV MCOV of energy discharged, while the VX arresters will increase 3.9°C per kJ/kV MCOV of duty.</p> <p>When the assumption is made that a total given length of line is charged to a maximum surge voltage level, a graphical estimate of the arrester response is possible using the switching-surge volt-ampere curve. Using line charge voltage and line surge impedance, a load line is superimposed on the switching-surge volt-ampere curve. The arrester discharge voltage and current are obtained from the point where the load line and volt-ampere curves intersect.</p> <p>The duration of the current obtained from a graphical solution can be estimated by:</p> $T_d = 2ZCL$ <p>where: T_d = time duration of current wave (seconds) Z = line surge impedance (Ω) C = line capacitance (farads/mile) L = line length (miles)</p> | <u>Arrester MCOV (kV)</u> | <u>Maximum Energy Discharge Capability (kJ/kV MCOV)</u> | 2.55 - 98 (VI, VIA, VR) | 3.4 (Currents 650 A or less) | 2.55 - 39 (VL, VLA) | 4.9 (Currents 1.0 kA or less) | 42 - 245 (VS, VN) | 8.9 (Currents 1.5 kA or less) | 318 - 485 (VX) | 16.2 (Currents 2.7 kA or less) | |
| <u>Arrester MCOV (kV)</u> | <u>Maximum Energy Discharge Capability (kJ/kV MCOV)</u> | | | | | | | | | | |
| 2.55 - 98 (VI, VIA, VR) | 3.4 (Currents 650 A or less) | | | | | | | | | | |
| 2.55 - 39 (VL, VLA) | 4.9 (Currents 1.0 kA or less) | | | | | | | | | | |
| 42 - 245 (VS, VN) | 8.9 (Currents 1.5 kA or less) | | | | | | | | | | |
| 318 - 485 (VX) | 16.2 (Currents 2.7 kA or less) | | | | | | | | | | |

OHIO BRASS

| TEXT | NOTES |
|---|-------|
| <p>Figures 10, 11 and 12 show the switching surge capabilities of DynaVar arresters expressed in terms of miles of line versus line charge voltage at the maximum arrester energy capability. The 242-kV, 362-kV and 550-kV systems using arresters with MCOV equal to maximum line-to-line voltage divided by $\sqrt{3}$ or 140-kV MCOV, 209-kV MCOV and 318-kV MCOV, respectively, are represented. An example in the use of curves: Considering the ANSI C62.1 transmission line discharge test parameters for a 362-kV system charged to 2.6 per unit with a 350-Ω surge impedance, the following capabilities in miles of line are noted.</p> <p>Single line - one operation, over 400 miles. Two parallel lines - one operation or single line - two operations, over 200 miles. Two parallel lines - two operations, over 100 miles.</p> <p><u>Operation from Transferred Surges</u></p> <p>The figures giving DynaVar capability for transmission line discharges assume that the arrester is installed at the system voltage of the line being switched. When a transformer and connected transmission line are switched together, the low-side arrester may operate, requiring the smaller arrester to discharge the higher-voltage line.</p> <p>Some TNA studies demonstrate the probability of low-side arrester failures caused by surge transfer from transformer high-side windings. Surge transfers with silicon-carbide arresters can occur when the per-unit sparkover of the low-side arrester is less than the per-unit sparkover of the high-side arrester; and, theoretically, the low-side arrester could be required to discharge the high-voltage line through a surge impedance reduced by the square of the transformer turns ratio. Although many low-side arresters undoubtedly have minimum sparkover levels well below the corresponding maximum sparkovers of the high-side arresters, this type of operation has not been a serious field problem in the past.</p> <p>Circuit arrangements in which sparkover of low-side arresters is a distinct possibility are those where no high-side breaker is provided and operating practices include closing the high-side line from a remote location before closing the low-side breaker. The two characteristics of transferred surges which determine the probability of arrester sparkover are the low-side oscillating component and the straight electromagnetic transfer.</p> <p>In the past, some utilities carefully selected silicon-carbide arresters for both high- and low-side transformer winding protection in order to prevent high-energy switching surges on the high-voltage circuits from being discharged by arresters on the low-voltage windings. These applications required coordination of the sparkover voltage of both high- and low-voltage windings. With metal-oxide arresters, this application is simplified due to the high nonlinearity of the blocks. Now it is only necessary to select a low-side arrester with about four percent more discharge voltage than the arrester on the high side, with both high- and low-side arrester discharge voltages expressed in per unit of MCOV.</p> <p>The following conservative guidelines will insure that low-side arresters will not be subjected to discharges in excess of their energy capabilities. For autotransformers, check if discharging the high-side transmission line through the low-side arrester will result in an energy discharge in excess of rating.</p> | |



OHIO BRASS

| TEXT | NOTES |
|---|-------|
| <p>Numbers in Figure 13 are based on the assumption that only the low-side arrester operates, and transformer inductance is neglected. The autotransformer inductance would make actual low-side operations less severe. Also, inductance probably would cause the high-side arrester to operate on + di/dt. For proper application, the discharge energy level (kJ/kV) should be equal to or less than the maximum capability in kJ/kV MCOV of the arrester shown in Figure 14.</p> <p>Where the possibility of low-side arrester duty in excess of energy rating exists, such as in all the 138-kV examples in Figure 13, use a low-side arrester MCOV with four percent higher discharge voltage than the high-side arrester discharge voltage times the transformer turns ratio.</p> $\text{Minimum } PL_L = 1.04 \times PL_H \times N$ <p>Where: PL_L = discharge voltage low-side PL_H = discharge voltage high-side N = turns ratio</p> <p>For example, assume a 525-kV/138-kV autotransformer uses a 318-kV MCOV high-side arrester and the 525-kV transmission line discharge can be severe. Use of Type VS-88 rather than Type VS-84 low-side arrester will assure high-side arrester operation also on any transferred surge where low-side duty would be otherwise severe.</p> <p>Alternately, the gapped VX design can be used on the high side and a gapless VN-84 can be used on the low side, since a VN has about five percent higher switching surge protection level than the VS.</p> <p>DynaVar arresters used on ungrounded circuits and subjected to transferred surges should be chosen from the severe-duty column of Figure 6 for normally recommended DynaVar arresters (MCOV equal to or greater than maximum line-to-line rms voltage divided by 1.25). For delta-to-wye surge transfers, MCOV arresters that normally would be used on the wye-connected side are adequate.</p> <p>Assuming proper current sharing requires that gapped VS and VX arresters be used on both the high and the low sides. Alternately, gapless VN can be used on both sides, or gapped arresters on the high side and gapless on the low side.</p> <p><u>Shunt Capacitor Bank and Cable Application</u></p> <p>Discharge currents from capacitor banks and cables can be higher than those from overhead lines, such that the arrester energy capability may be less than previously shown.</p> <p>However, assuming no switching malfunction or restrikes, Figure 15 applies to capacitor banks and Figure 16 to cables on grounded neutral systems using normally recommended MCOV arresters. This is true for all source reactances normally encountered.</p> <p>For example, a 145-kV (138-kV nominal) shunt bank protected by 84-kV MCOV DynaVar arresters can be as large as: $2.7 \times 145 = 391$ MVAR.</p> <p>A 145-kV cable of 0.4 microfarad/mile, using the same 84-kV MCOV DynaVar arresters, can be as long as:</p> $\frac{7000}{145 \times 0.4} = 120 \text{ miles}$ | |

OHIO BRASS

| TEXT | NOTES |
|--|-------|
| <p><u>Temporary 60-Hz Overvoltage Capability</u></p> <p>In addition to the requirement for continuously withstanding the maximum normal line-to-ground system voltage, DynaVar arresters may infrequently be required to withstand a 60-Hz voltage in excess of maximum continuous operating voltage (MCOV). The most common cause is voltage rise on unfaulted phases during a line-to-ground fault. Such voltages can be calculated using the method of symmetrical components. For an effectively grounded system, coefficient of grounding less than or equal to 0.8, the maximum overvoltage by definition will be equal to or less than 1.4 times maximum normal line-to-ground voltage.</p> <p>Other situations can exist that will result in yet higher temporary power frequency voltages. One typical example is voltage rise due to feeding a capacitive load such as a long unloaded and uncompensated EHV line through a generator, transformer and line inductance (Ferranti effect). Other causes include sudden loss of load, backfeeding isolated sections of line through a small transformer, loss of neutral ground due to backfeeding through a delta-connected high-side transformer, and 60-Hz resonant conditions.</p> <p>Once the possible magnitude and duration of these overvoltage conditions are established by analog or digital computer study or operating experience, the effect on arrester selection can be evaluated. For situations in which the duration of such overvoltages can be extended (seconds or minutes), DynaVar VS and VX station arresters should be chosen such that minimum 60-Hz sparkover will not be exceeded. When the overvoltage will be of a dynamic nature lasting a number of cycles, arrester operations are permissible up to the maximum energy capability of the arrester.</p> <p>Figure 17 shows 60-Hz overvoltage capability for prolonged overvoltages that do not exceed VS or VX arrester sparkover. Even if operating at 60°C and having absorbed maximum rated energy, the arrester could be energized at 1.37 times MCOV for one minute.</p> <p>Figure 18 shows the minimum 60-Hz sparkover versus arrester temperature. As previously mentioned, arrester temperature can be calculated from initial ambient temperature plus temperature rise due to immediately preceding surge duty. The arrester temperature can rise 8.3°C for each kJ/kV MCOV of dissipated energy for VS arresters from 42 to 245-kV MCOV. The corresponding temperature rise for VX arresters 318 kV and above is 3.9°C for each kJ/kV MCOV of energy.</p> <p>Figures 19 and 20 indicate the time in cycles it will take an arrester to reach its maximum energy capability. The overvoltage magnitude is given in per unit of DynaVar MCOV and is the prospective voltage without the arrester in the circuit. Separate curves are shown for available short circuit currents of 500-A, 1.5-kA and 5-kA rms for VS arresters and 1-kA, 3-kA and 10-kA rms for VX arresters. Arrester sparkover is assumed every half-cycle.</p> <p>Prospective circuit voltage is sinusoidal, which results in the withstand times being conservative for overvoltages with high harmonic content.</p> <p>Since DynaVar Types VL and VN station, Type VI intermediate, and Type PVR riser-pole arresters do not have the gapped</p> | |



OHIO BRASS

| TEXT | NOTES |
|---|-------|
| <p>linear impedance to enhance temporary voltage capability, the duration of the overvoltage is less than for other gapped station class designs. Figure 21 illustrates the temporary overvoltage of these gapless arresters.</p> <p><u>Comparison of MPR and DynaVar Insulation Coordination and Protective Margins</u></p> <p>The table in Figure 22 compares silicon-carbide MPR and DynaVar protective characteristics for typical 138-kV, 345-kV and 500-kV system arresters. The figures assume that the arrester lead lengths and transformer separation distances are negligible and are, thus, strictly applicable only where the arresters are applied at the transformer location. They do, however, reveal the relative improvements in protective margins possible with DynaVar arresters.</p> <p>For a 138-kV system, the insulation coordination is shown for a 450-kV BIL transformer with four different arresters: MPR 108 kV, MPR 120 kV and DynaVar VS 84 kV and VN 84 kV. A 345-kV, 900-kV BIL transformer withstand voltage characteristic is plotted with the protective characteristics of MPR 258-kV, MPR 276-kV and DynaVar VS 209-kV and VN 209 kV arresters. Protective margins are calculated by comparing the transformer withstand levels and arrester protective levels as listed previously. A coordination current of 10 kA is used for 138-kV and 345-kV systems, and a coordination current of 15 kA is used for the 500-kV system.</p> <p>Figures 23 through 30 compare the protective margins obtained in nine examples of insulation coordination. When equivalently sized MPR and DynaVar arresters are compared (DynaVar kV = MPR kV x 0.81), BIL margins are about the same while substantial improvements for chopped-wave and BSL margins are obtained. Smaller DynaVar arresters may be applicable in many instances, which will result in further increased margins at all three coordination points.</p> | |

OHIO BRASS

TEXT

NOTES

**DynaVar VS-209 Voltage-Current Curve
Compared to MPR 258 and Linear Resistance**

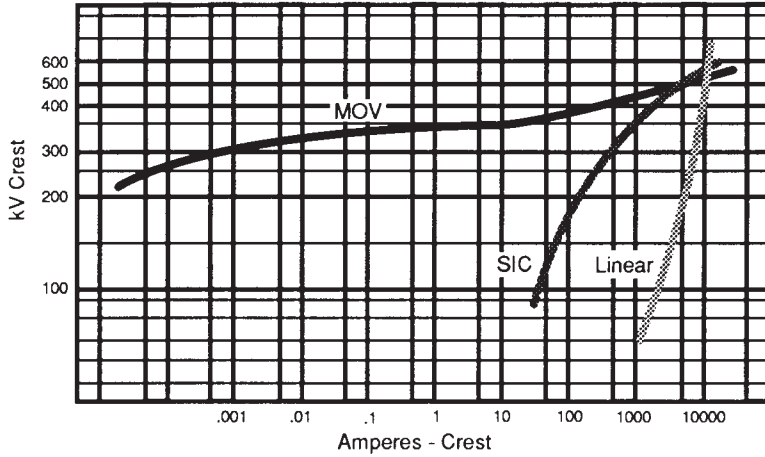

Figure 1

Section Views of Typical Units

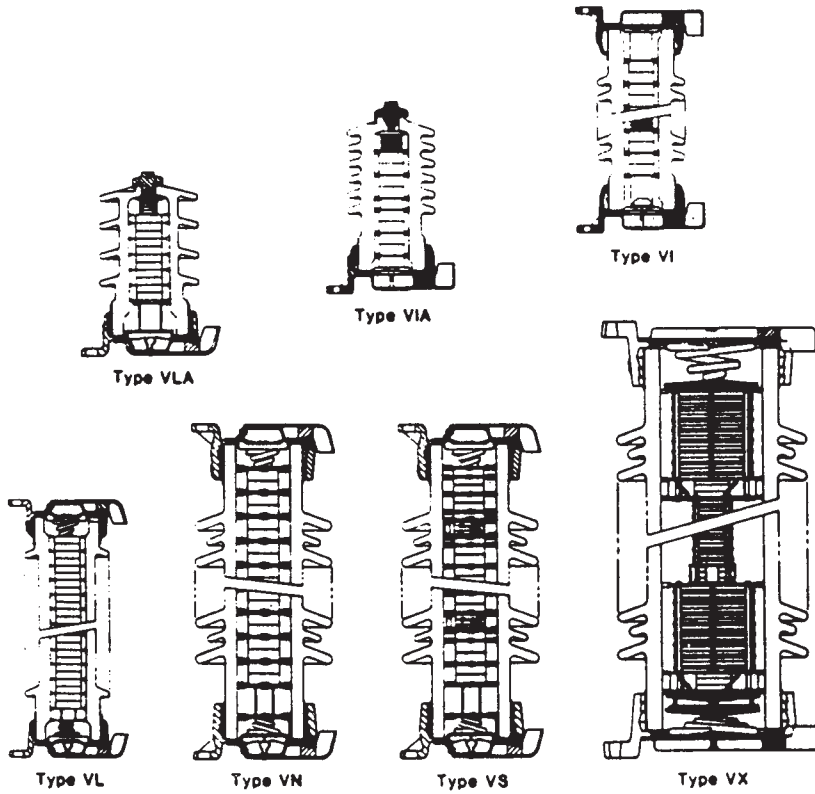

Figure 2

OHIO BRASS

TEXT

NOTES

Line-to-ground Sustained Voltage for Grounded Systems*

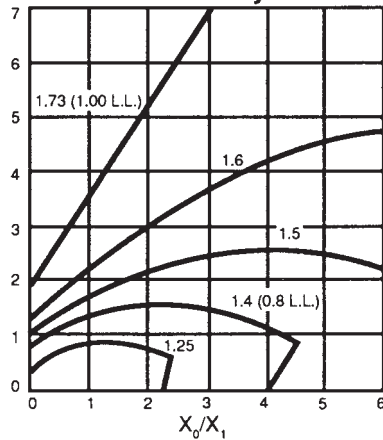

*Region of small X_0/X_1 and R_0/X_1

Figure 3

Sparkover Versus Temperature DynaVar VS and VX

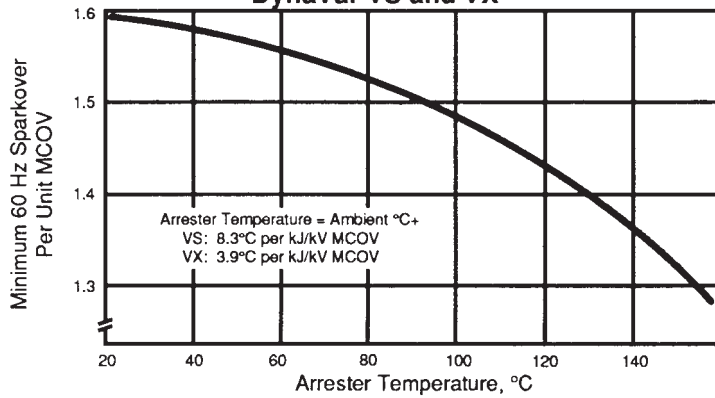

Figure 4

60-Hz Temporary Overvoltage Capability For Gapless ZnO Arrester DynaVar VL and VN

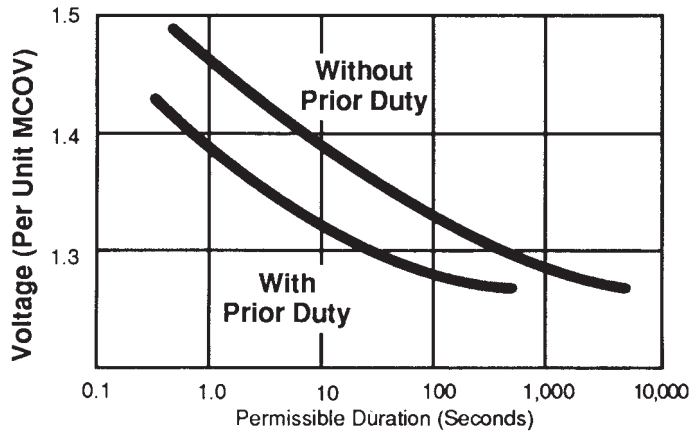

Figure 5

OHIO BRASS

TEXT

NOTES

**Table I -
Normally Recommended
DynaVar VS and VX
MCOV For Various System Voltages**

| System L-L Voltage kV | | Arrestor MCOV - kV | | |
|-----------------------|---------|---------------------------|--|-----|
| | | Grounded Neutral Circuits | Temporarily Ungrounded, Impedance Grounded Or Ungrounded Circuits Type VS and VX | |
| Nominal | Maximum | | (1) | (2) |
| 69 | 72.5 | 42 | 52 | 57 |
| 115 | 121 | 70 | 88 | 98 |
| 138 | 145 | 84 | 108 | 115 |
| 161 | 169 | 98 | 131 | 140 |
| 230 | 242 | 140 | 180 | 209 |
| 345 | 362 | 209 | — | — |
| 400 | 420 | 245 | — | — |
| 525 | 550 | 318 | — | — |
| 765 | 800 | 470 | — | — |

Figure 6

**Table II -
Normally Recommended
DynaVar VL and VN
MCOV For Various System Voltages**

| System L-L Voltage kV | | Arrestor MCOV - kV | | |
|-----------------------|---------|---------------------------|--|------|
| | | Grounded Neutral Circuits | Temporarily Ungrounded, Impedance Grounded Or Ungrounded Circuits Type VL and VN | |
| Nominal | Maximum | | (1) | (2) |
| 2.4 | 2.52 | 2.55 | 2.55 | 2.55 |
| 4.16 | 4.37 | 2.55 | 5.1 | 5.1 |
| 4.8 | 5.04 | 5.1 | 5.1 | 5.1 |
| 6.9 | 7.25 | 5.1 | 7.65 | 7.65 |
| 8.32 | 8.74 | 5.1 | 7.65 | 8.4 |
| 12.0 | 12.6 | 7.65 | 10.2 | 12.7 |
| 12.47 | 13.1 | 7.65 | 12.7 | 12.7 |
| 13.2 | 13.9 | 8.4 | 12.7 | 12.7 |
| 13.8 | 14.5 | 8.4 | 12.7 | 15.3 |
| 20.78 | 21.8 | 12.7 | 19.5 | 22 |
| 22.86 | 24.0 | 15.3 | 19.5 | 22 |
| 23.0 | 24.2 | 15.3 | 19.5 | 22 |
| 24.94 | 26.2 | 15.3 | 22 | 24.4 |
| 34.5 | 36.2 | 22 | 29 | 36.5 |
| 46 | 48.3 | 29 | 39 | 48 |
| 69 | 72.5 | 42 | 57 | 70 |
| 115 | 121 | 70 | 98 | 115 |
| 138 | 145 | 84 | 115 | 131 |
| 161 | 169 | 98 | 140 | 152 |
| 230 | 242 | 140 | 209 | 220 |
| 345 | 362 | 209 | — | — |
| 400 | 420 | 245 | — | — |
| 525 | 550 | 318 | — | — |
| 765 | 800 | 470 | — | — |

Figure 7

OHIO BRASS

TEXT

NOTES

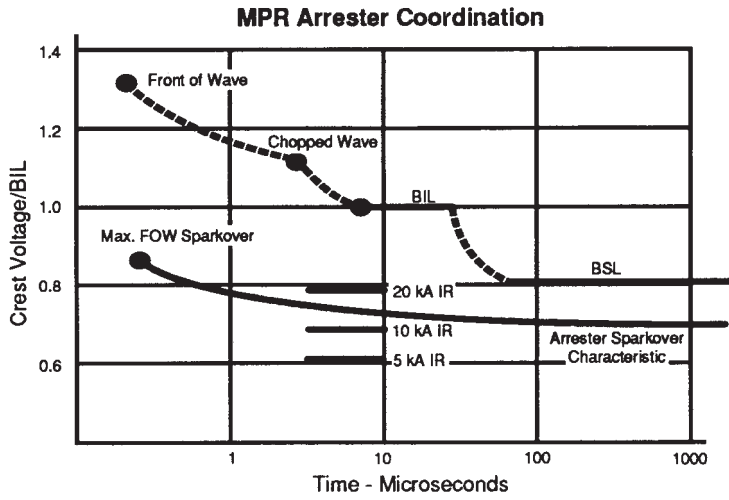

Figure 8

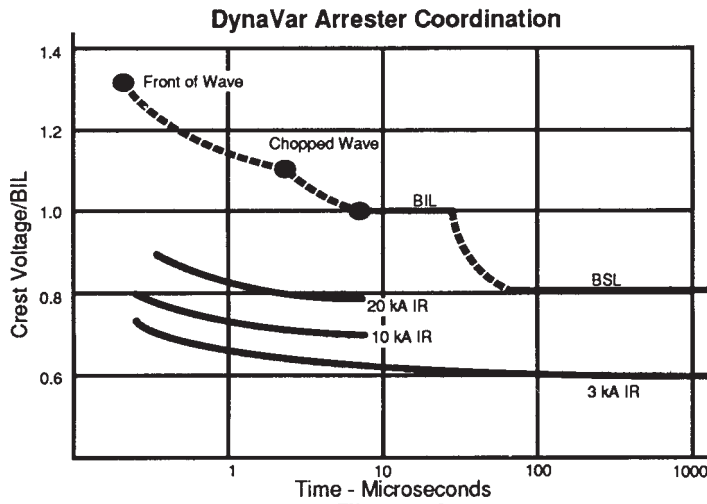

Figure 9

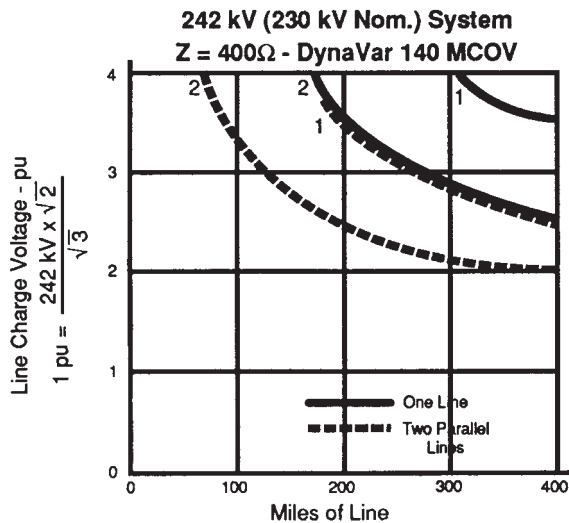
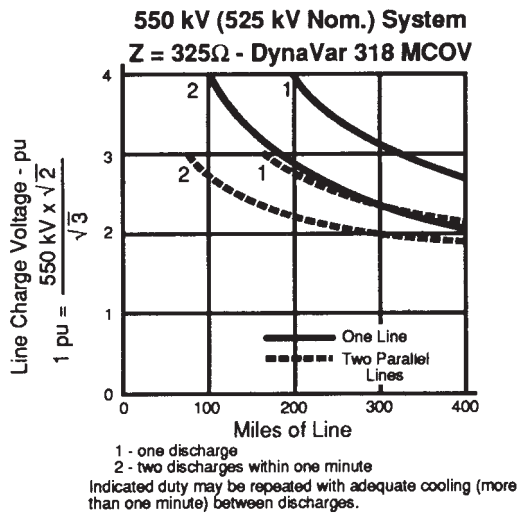
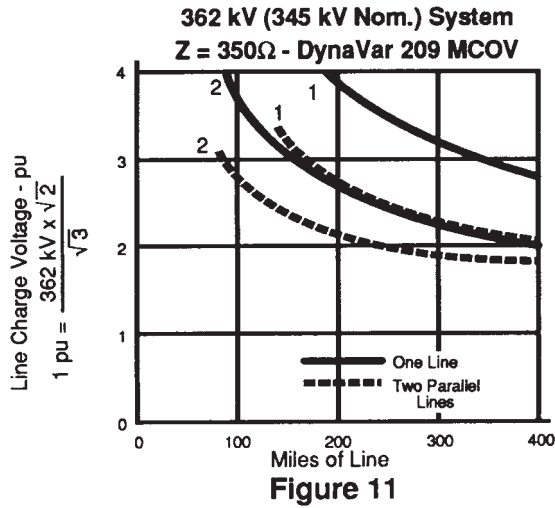

Figure 10

OHIO BRASS

TEXT

NOTES



ANSI C62.1 Transmission Line Discharges Calculated for Transfer Through Autotransformer to Low-Side DynaVar Arresters (For Type VS and Type VX Arresters)

| Transformer kV | — High-Side Arresters — | | | | — Low-Side Arresters — | | | |
|-------------------|-------------------------|-----|------|---------------|------------------------|-----|------|---------------|
| | Amps | kV | kJ | kJ/kV MCOV | Amps | kV | kJ | kJ/kV MCOV |
| 345/138 | 950 | 441 | 880 | 4.2 | 2200 | 185 | 855 | 10.2 |
| 345/161 | 950 | 441 | 880 | 4.2 | 1900 | 215 | 858 | 8.8 |
| 345/230 | 950 | 441 | 880 | 4.2 | 1360 | 301 | 860 | 6.1 |
| 525/138 | 720 | 664 | 1100 | 3.5 | 2200 | 185 | 935 | 11.1 |
| 525/161 | 720 | 664 | 1100 | 3.5 | 2000 | 216 | 994 | 10.1 |
| 525/230 | 720 | 664 | 1100 | 3.5 | 1500 | 301 | 1038 | 7.4 |
| 525/345 | 720 | 664 | 1100 | 3.5 | 1050 | 441 | 1065 | 5.1 |
| 765/138 | 1100 | 987 | 2500 | 5.4 | 4000 | 193 | 1780 | 21.2 |
| 765/230 | 1100 | 987 | 2500 | 5.4 | 2900 | 312 | 2080 | 14.8 |
| 765/345 | 1100 | 987 | 2500 | 5.4 | 2100 | 462 | 2230 | 10.6 |
| 765/525 | 1100 | 987 | 2500 | 5.4 | 1480 | 693 | 2260 | 7.4 |

Figure 13

OHIO BRASS

| TEXT | NOTES |
|------|-------|
|------|-------|

**Transferred ANSI C62.1 Transmission Line
Discharge Energy Capability For DynaVar**

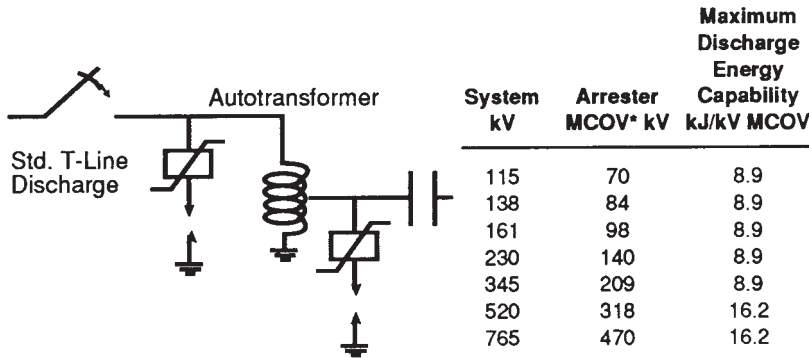

* Maximum continuous operating voltage, line to neutral, applied to the arrester.

Figure 14

SHUNT CAPACITOR BANKS

(DynaVar MCOV = Maximum System L-G Voltage)

MCOV = 2.55 to 39 kV:

$$3\phi\text{MVAR} = 1.5 \times \text{Max. System L-L Voltage (kVrms)}$$

MCOV = 42 to 245 kV:

$$3\phi\text{MVAR} = 2.7 \times \text{Max. System L-L Voltage (kVrms)}$$

MCOV = 318 to 485 kV:

$$3\phi\text{MVAR} = 5.4 \times \text{Max. System L-L Voltage (kVrms)}$$

Figure 15

CABLES

(DynaVar MCOV = Maximum System L-G Voltage)

MCOV = 42 to 245 kV:

$$\text{Cable Miles} = \frac{7000}{\text{Max. System L-L Voltage (kVrms)} \times \mu\text{F/mile}}$$

MCOV = 318 to 485 kV:

$$\text{Cable Miles} = \frac{14\ 300}{\text{Max. System L-L Voltage (kVrms)} \times \mu\text{F/mile}}$$

Figure 16

OHIO BRASS

TEXT

NOTES

**60 Hz Temporary Overvoltage Capability
DynaVar VS and VX**

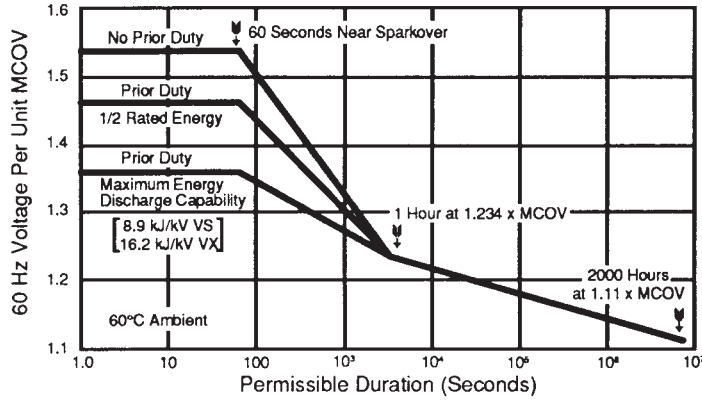

Figure 17

**Sparkover Versus Temperature
DynaVar VS and VX**

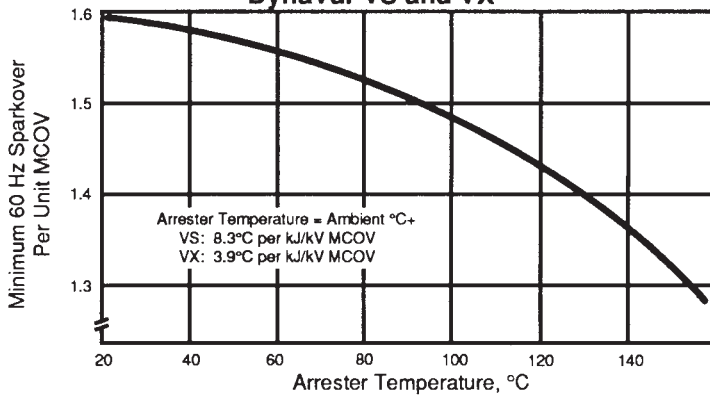
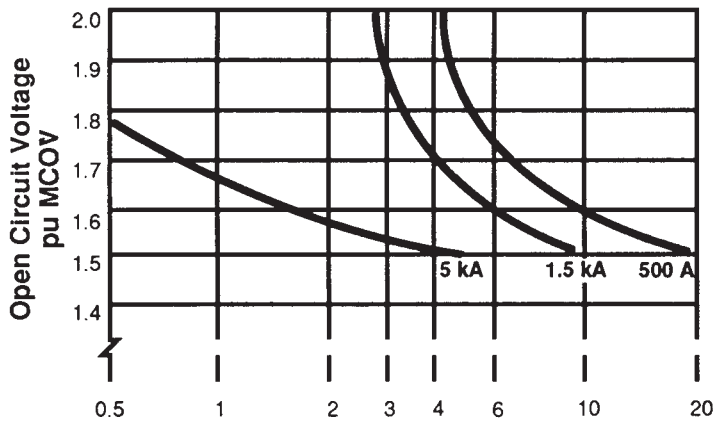

Figure 18

Arrester MCOV 42 to 245 kV



Time -- Cycles of 60 Hz

Temporary dynamic overvoltage capability if gap is sparked over every half-cycle. The currents identifying the curves are the prospective system fault currents at the arrester location during the overvoltage.

Figure 20

OHIO BRASS

TEXT

NOTES

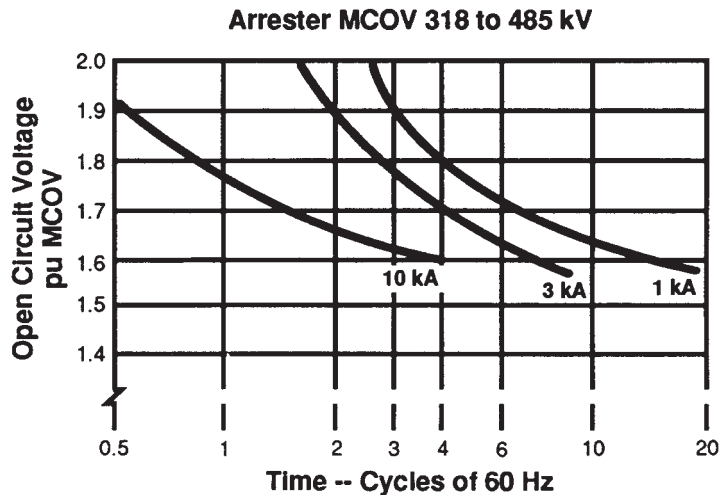

Temporary dynamic overvoltage capability if gap is sparked over every half-cycle. The currents identifying the curves are the prospective system fault currents at the arrester location during the overvoltage.

Figure 20

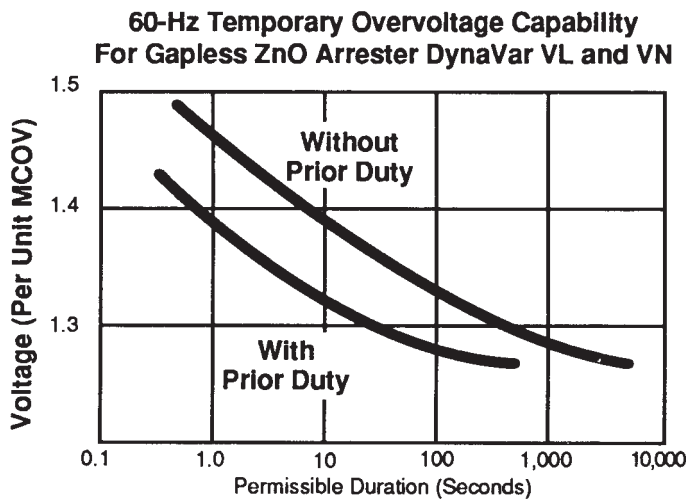

Figure 21

Summary of DynaVar and MPR Protective Margins

| Arrester (kV) | System Nominal (kV) | CWW (kV) | % Margin | BIL (kV) | % Margin | BSL (kV) | % Margin |
|---------------|---------------------|----------|----------|----------|----------|----------|----------|
| (I) MPR 108 | 138 | 495 | 52 | 450 | 84 | 375 | 53 |
| MPR 120 | | | 38 | | 65 | | 38 |
| VS 84 | | | 87 | | 92 | | 84 |
| VN 84 | | | 85 | | 85 | | 94 |
| (II) MPR 258 | 345 | 990 | 25 | 900 | 54 | 745 | 27 |
| MPR 276 | | | 18 | | 43 | | 18 |
| VS 209 | | | 50 | | 54 | | 47 |
| VN 209 | | | 49 | | 49 | | 44 |
| (III) MPR 396 | 525 | 1,430 | 23 | 1,300 | 36 | 1,080 | 22 |
| MPR 420 | | | 16 | | 29 | | 15 |
| VX 318 | | | 34 | | 42 | | 40 |

Figure 22

OHIO BRASS

TEXT

NOTES

**Insulation Coordination -- 138 kV System 450 kV BIL
MPR 120 kV Arrester**

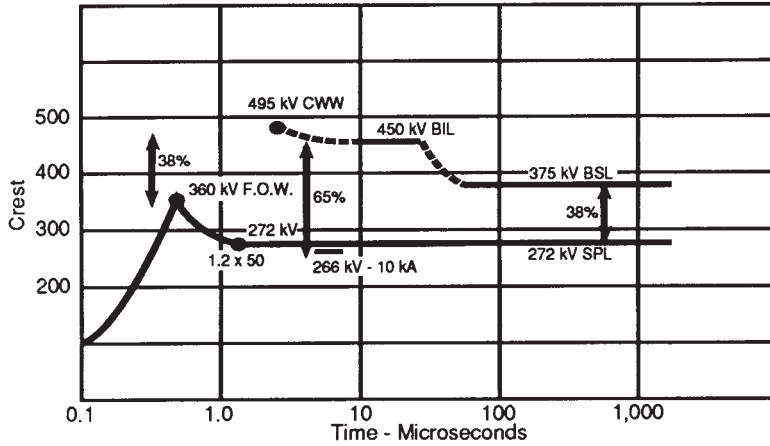

Figure 23

**Insulation Coordination -- 138 kV System 450 kV BIL
MPR 108 kV Arrester**

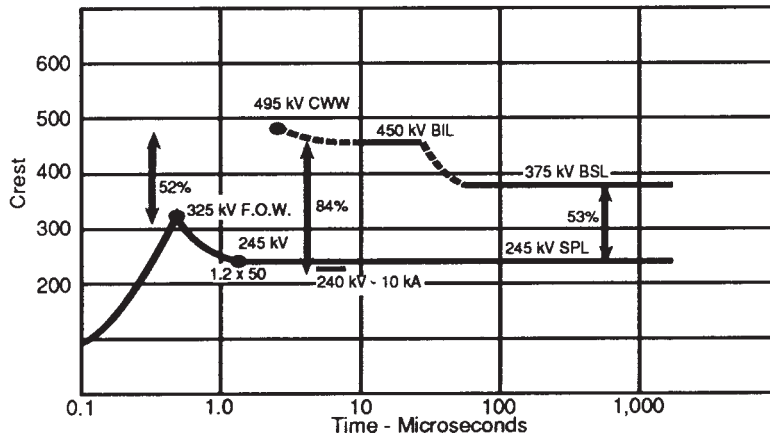

Figure 24

**Insulation Coordination -- 138 kV System 450 kV BIL
DynaVar VS 84 kV Arrester**

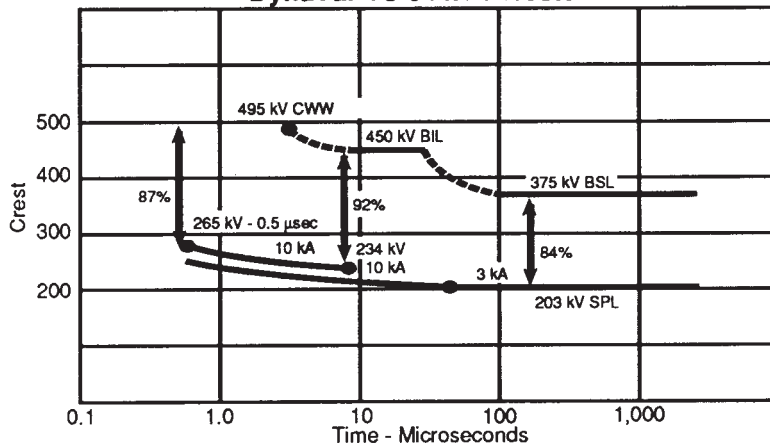

Figure 25

OHIO BRASS

TEXT

NOTES

**Insulation Coordination -- 138 kV System 450 kV BIL
DynaVar VN 84 kV Arrester**

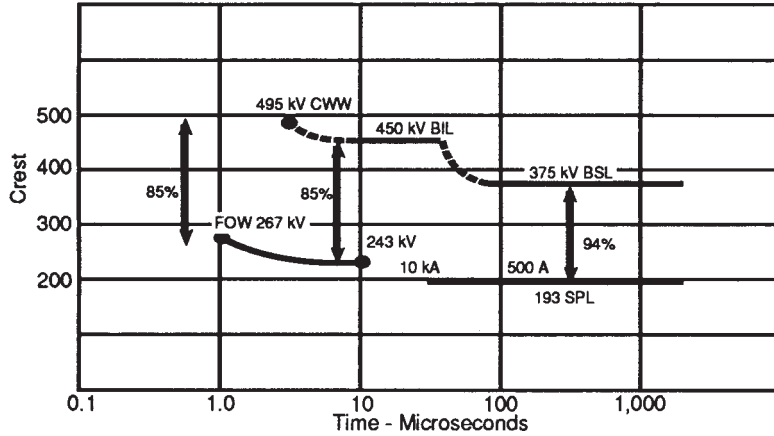

Figure 26

**Insulation Coordination -- 345 kV System 900 kV BIL
MPR 276 kV Arrester**

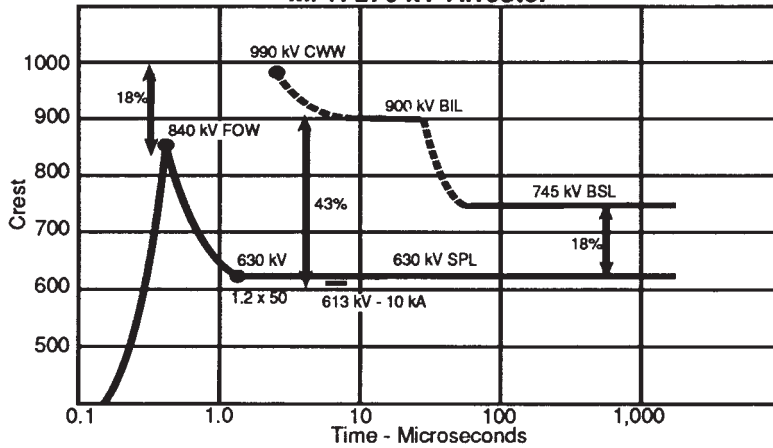

Figure 27

**Insulation Coordination -- 345 kV System 900 kV BIL
MPR 258 kV Arrester**

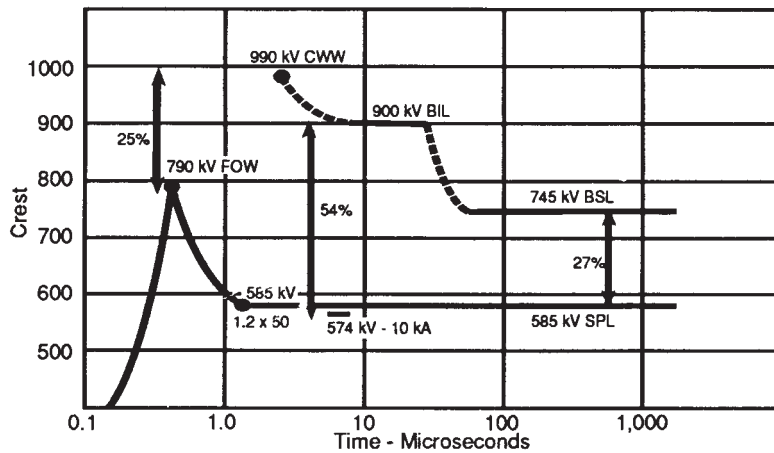

Figure 28

OHIO BRASS

TEXT

NOTES

**Insulation Coordination -- 345 kV System 900 kV BIL
DynaVar VS 209 kV Arrester**

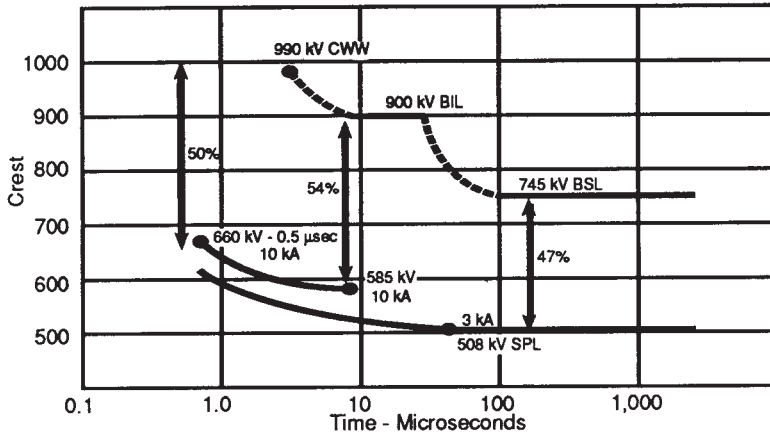

Figure 29

**Insulation Coordination -- 345 kV System 900 kV BIL
DynaVar VN 209 kV Arrester**

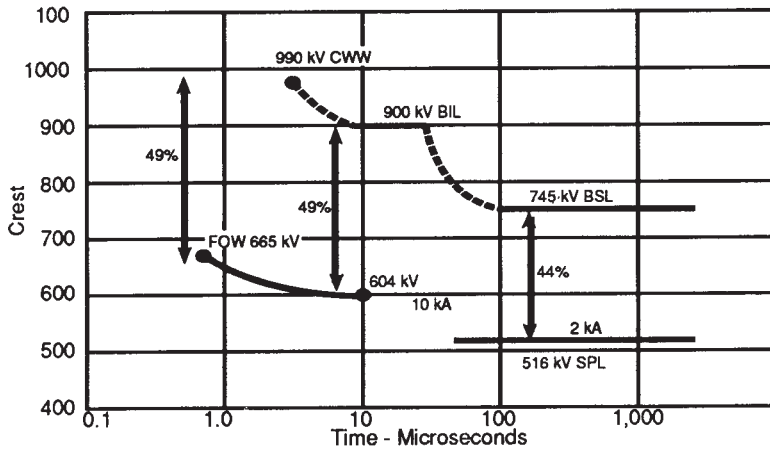

Figure 30