

# POLYCAST®

## DG0657R

600 Series Double  
Stainless Steel Perforated

PROJECT ID/  
CONTRACT NO: \_\_\_\_\_

LOCATION: \_\_\_\_\_

### ENGINEERING SPECIFICATION:

POLYCAST® DG0657R Grate is designed for use where sanitary conditions are essential, as well as the need for heel-resistant grating. Grating locking device Part No. DA0642S (not shown) should be used and maintained secure. The grate has 17% (34in<sup>2</sup>) of open area. The grate is made 14 gauge GR. 304 Stainless Steel and weighs approximately 12lbs [5.44kg]. The grate is available in both 24" [610mm] and 48" [1219mm] lengths.

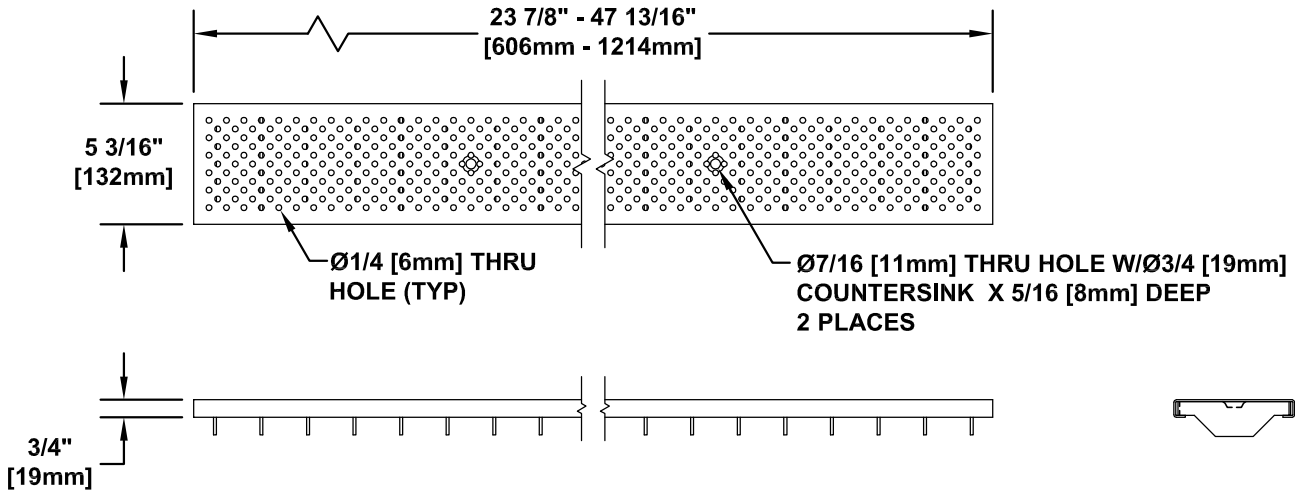
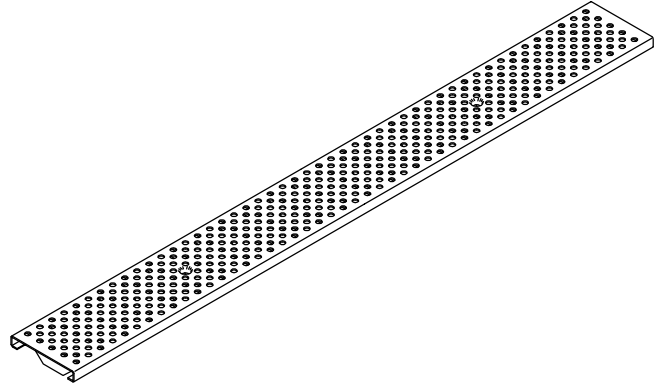

### DIN APPLICATION LOAD CLASS C:

Curb sides, highway shoulders, and parking areas  
Designed for a distributed pressure of 56,200 lbs (250 kN).

### Meets the following Standards & Specifications:

- DIN 19580 / DIN EN 1433 Drainage Channels for Vehicular and Pedestrian Areas
- The Americans with Disabilities Act of 1990: 4.5.4
- ASME A112.6.3: Section 7.12 Heel Resistant Strainers and Grates
- Australian Standard AS 3996-2006 Clause 3.3.6



www.polycastdrain.com  
Toll Free Number:  
1-800-346-3062