

CAPSTAN HOIST SAFETY



TIPS & NEWS Reprinted from
Vol. 2, No. 1
reprint JANUARY 1996



CAPSTAN HOIST

follow these recommendations

SAFETY



Capstan hoisting devices have been used to lift or move heavy loads for centuries. Chance Series 90 capstans make back-breaking work fast, easy and productive.

Safety is the most important consideration in work. A shortcut or misapplication of equipment can cause damage, injury or worse. Follow these safety tips when using capstan hoists:

...continued



1

NEVER OVERLOAD THE HOIST!

Always take the time to understand the job at hand, the equipment being used, and the procedures required to perform the task. Every Chance capstan comes with an instruction booklet and a label on the hoist. Read both of these documents carefully and be sure you understand all the warnings before using the product. A capstan makes moving a load so effortless for the operator that the operator does not have a "feel" for the weight as when using a block and tackle. Because of this, the operator must know what the weight of the object or the force to pull the cable will be before starting the job.

Remember: These hoists are for lifting equipment or pulling cable, not for lifting personnel.

Never lift people or loads over people.

2

NEVER MOVE A LOAD THE OPERATOR CANNOT SEE WITHOUT PROPER COMMUNICATION.

Many times the hoist operator cannot be located in a position to view the load being moved. In these cases, communication with a second worker watching the load is necessary. Standardized hand signals have been developed for this purpose. In some remote cases radio communication may be necessary.

3

NEVER USE A MALFUNCTIONING OR DAMAGED HOIST!

Before every job thoroughly inspect the work site and equipment to spot dangers. Inspect the hoisting equipment for proper function, bent, broken, or missing parts damaged in previous jobs. Make sure all of the equipment being used is rated for the loads involved.

4

BEWARE OF POTENTIAL DANGER ZONES AND STAY CLEAR.

The arranging of equipment or "rigging" for a job is extremely important. Proper rigging makes a job easy. Improper rigging can make a job unsafe. The crew must analyze each job to determine the equipment required and the possible location for each piece of equipment. Several options may be available, so careful thought must be given to choose the safest arrangement possible. Analyze the forces, direction of those forces, and what can happen if something breaks during the job.

Most things are stronger in compression than tension or bending. If you have a choice, use an item in compression.

For example, mount the bracket so the load pulls the bracket against, instead of away from, the pole. This puts less tension on the clamps. It is also better to pull in a direction that is "in line" with a pole rather than a direction that will try to turn the hoist and bracket "around" the pole.

The proper choice of hoist, bracket, clamping means, rope, blocks, slings, and gins are but a few of the items to be considered. Take, for example, selection of a rope sheave. If a single sheave rope block is used to lift a transformer weighing 400 lb. it must be rated for 900 lb. minimum. Why? The load (400 lb.) is pulling down on the block. At the same time the hoist has to pull 400 lb. to lift the load. This pull is also pulling down on the block. So 400 lb. (load) plus 400 lb. (hoist pull) equals 800 lb. downward load on the block. Friction will add additional load on the block so that must be taken into account also. 10 percent of the load is a rule of thumb that may be used for friction, so 800 lb. plus 80 lb. (10%) equals 880 lb. The same is true for a gin or sling used to support the block.

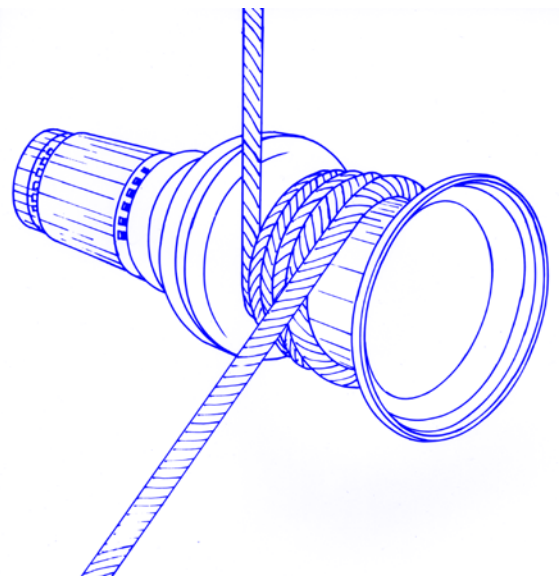

The rope to be used over a capstan drum needs three things: Adequate working load, good frictional characteristics, and high temperature melting point. As rope goes around a capstan drum, it must slip a minute amount to advance across the drum. This creates friction which causes the drum to heat. If the drum is allowed to rotate without advancing the rope, heat builds up quickly and melts plastic ropes.

WARNING: Allowing the drum to turn without advancing the rope is a dangerous condition as the melted rope may break or "weld" to the drum which will then wrap up the rope like a winch. Chance recommends a composite fiber braided rope like our Catalog Number C400-0586. This rope has low stretch and excellent gripping power on a capstan.

Always mount the hoist to the proper bracket using the high strength bolts and fasteners supplied with each hoist. If fasteners are damaged or missing, replace them with the same type and grade designation. The fasteners must be tightened evenly to the proper torque to insure "load sharing" by all the fasteners.

Follow the directions in the owners manual for installing the bracket on the pole or other structure to be used. Align the capstan drum so the rope will feed perpendicular to the drum axis and onto the large radius of the drum near the motor end.

This allows rope to feed smoothly across the drum as the load is moved. Do not allow the load line to rub on the pole or other objects as this will degrade the rope. Be sure to retighten the chain binders after initial loading to compensate for "seating" of the chain and bracket into the pole.



5

NEVER OPERATE A HOIST WITHOUT THE FOOT CONTROL.

The hoist is started and stopped by a foot operated control. Stepping on the control starts the drum turning and releasing pressure on the control stops the hoist.

...continued 

6

THREE VERY IMPORTANT THINGS TO REMEMBER ABOUT TURNS OF ROPE ON THE DRUM:

Never add or remove turns of rope while a load is suspended. Use the same number of turns to lower a load as is required to raise the load. And, never use so many turns of rope that no pull is required on the fall line to activate the load.

If any of the above rules are broken, the operator could lose control, or drop the load.

After the hoist, bracket, and foot control are properly installed, you are ready to start lifting or pulling. Bring the rope from the load through the necessary blocks and to the capstan drum. All of the Chance hoist drums rotate in a counter-clockwise direction when viewed from the drum end. Wrap the pulling rope around the drum in this direction starting with the load line nearest the motor end of the drum. The number of turns of rope around the drum is determined by the load to be lifted. The chart below illustrates the advantage of the hoist based on the number of turns of rope on the drum. On the left side find 3.5 turns, follow the horizontal line to the graphed line, then vertically down to the bottom which falls at 30. This means for every pound of

pull on the fall line, the hoist applies 30 lb. to the load line. Thus, a 600 lb. load can be lifted with 20 lb. pull on the fall line using 3.5 turns of rope on the drum. Select the number of turns which will allow control of the load with 20 to 40 lb. pull on the fall line

The graph and diagram below show capstan principle in action. Operator effort remains low for typical loads simply by adding wraps on the capstan drum. So little effort is required, any crew member can run the hoist. Control is so accurate, loads can be moved fractions of an inch.

Example: 4 wraps of rope = 1:44 ratio. That is, 1 lb. pull on fall line develops 44 lb. on load line. Therefore, 20 lb. of pull develops 880 lb. of lift.

Lifting the load or pulling cable is a simple matter of starting the hoist by stepping on the foot control and applying pull to the fall line. Continue a steady pull, hand over hand, to complete the lift. When the load is near the final point, slow down on the fall line pull to ease the load into position. With minimal practice, the operator can place the load within a fraction of an inch. Once the load is in place, lifting the foot from the control stops the hoist. The Chance hoist is equipped with an anti-reversing brake which keeps the drum from turning backwards. This allows the load to be held in position by holding the fall line. If the load needs to be lowered, simply allow the rope to slip back around the drum slowly, allowing the operator to lower the load safely and in full control.

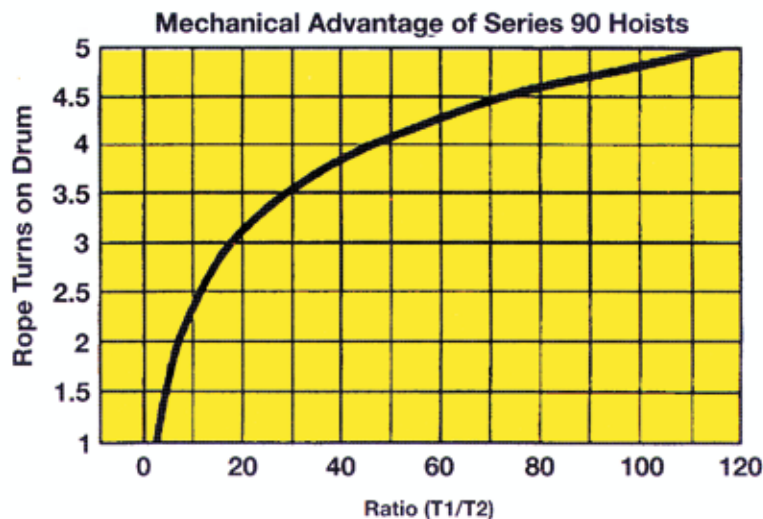
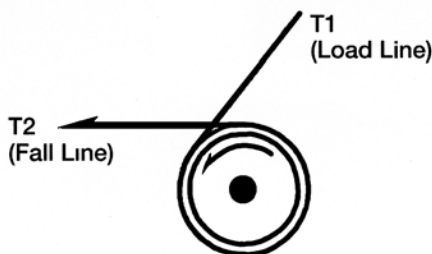



7

AN OPTIONAL ROPE LOCK ATTACHMENT IS AVAILABLE

for the Series 90 hoists, which allows the operator to hold a load in position without having to tie knots or hold the rope. With the fall line fed through the rope lock, the device automatically grips the rope to hold the load whenever the operator stops pulling.

A capstan hoist is a versatile tool for lifting, or pulling heavy loads. A few minutes of thought and preparation will make your lifting jobs safe and efficient. ■

**UNITED STATES
CANADA, INTERNATIONAL**

HUBBELL POWER SYSTEMS, INC.
210 N. Allen Street
Centralia, Mo 65240-1395
Phone: 1-573-682-5521
Fax: 1-573-682-8714
e-mail: hpsliterature@hps.hubbell.com

MEXICO

HUBBELL DE MEXICO, S.A. DE C.V.
Av. Insurgentes Sur #1228, Piso 8
Col. Tlacoquemacatl Del Valle
Mexico, D.F. 03200
Phone: 52-55-9151-9999
Fax: 52-55-9151-9988
Website: hubbell.com.mx

**Web: <http://www.hubbellpowersystems.com>
E-mail: hpsliterature@hps.hubbell.com**

TIPS & NEWS Reprinted from
Vol. 2, No. 1
reprint JANUARY 1996

BUSHINGS • CONSTRUCTION • INSULATION • PROTECTION • SWITCHING • TOOLS



CHANCE

NOTE: Because Hubbell has a policy of continuous product improvement, we reserve the right to change design and specifications without notice.

©Copyright 2009 Hubbell Incorporated

Printed in USA

Bulletin 20-9601
Rev. 9/09 RGS