

HUBBELL[®] TIPS & NEWS

Vol. 7 No. 2 AUGUST 2002

<http://www.hubbellpowersystems.com>



New Line **RECLOSER BY-PASS SWITCHES** PATENT PENDING

- Three-Pull Type for Distribution
- Fused Combination Type for Substations

Now you have a choice of switches to by-pass and isolate a recloser. Available in Distribution-Class and Station-Class ratings, Hubbell By-Pass Switches help keep your customers' service continuous during routine maintenance and repairs of your system reclosers.

FUNCTION-FORMED PARTS DELIVER OPERATING EASE

Their simple-to-operate hookstick design makes these switches easy to use. Their construction employs current-carrying components of the M3 Disconnect Switch and the Fused By-Pass Switches use the Type C Cutout fuse holder.

In normal operation, the Distribution Type By-Pass Switch blade is open and the two disconnect blades are closed, allowing the recloser to be in the circuit. When it is desired to remove the recloser from the circuit, the by-pass blade first is closed to provide a parallel current path. Then the recloser's internal contacts are opened. Last, both disconnect blades of the by-pass switch are opened.

This maintains service continuity while isolating the recloser from the line. Reversing the procedure returns the recloser to service.

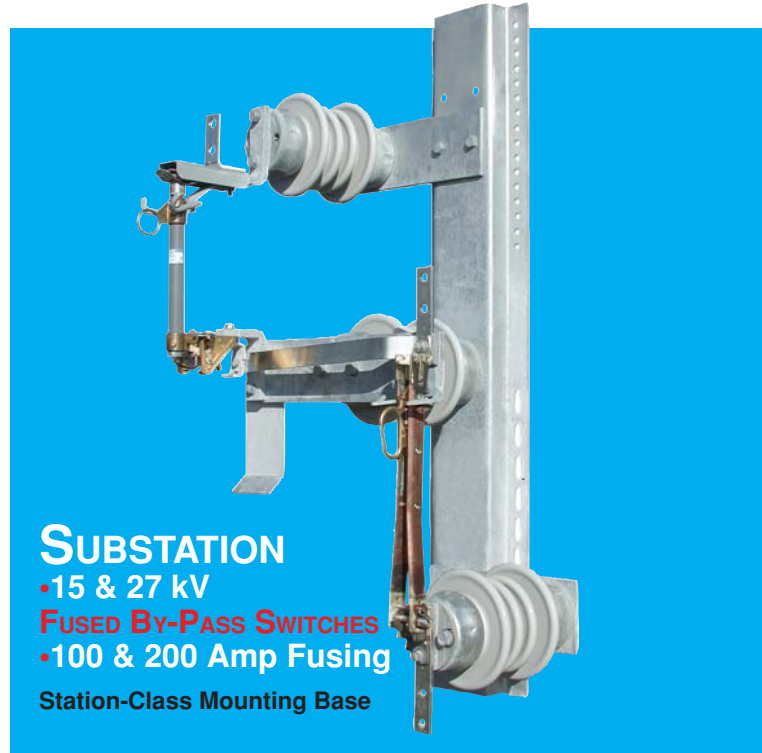

SUBSTATION
 • 15 & 27 kV
FUSED BY-PASS SWITCHES
 • 100 & 200 Amp Fusing
 Station-Class Mounting Base



DISTRIBUTION
 • 14.4, 25 & 34.5 kV
THREE-PULL BY-PASS SWITCHES

Back Strap Mounting and Pole Mounting variations available

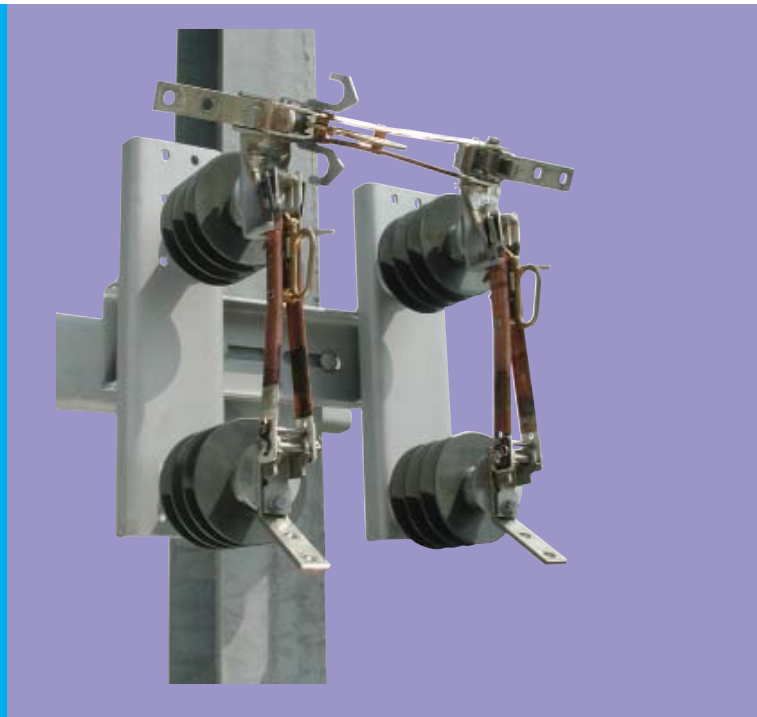

FUSED SWITCH PROTECTION SUBSTITUTES FOR RECLOSER

The Fused Type BPF By-Pass Switch consists of a 600 Amp loadbreak disconnect switch in series with a Type C cutout fuse holder, which provides protection to the circuit while the recloser is out of service. Both devices are on a common mounting channel for ease of installation. 100 and 200 Amp fuse holders are available to fit specific applications. The fuse holder may be specified on either the right- or left-hand side of the switch.

Operation typically is with a companion M3S disconnect switch. In normal operation, the fuse holder is disconnected. To bypass the recloser, the fuse holder with proper fuse is closed and the series disconnect blade

For Distribution Lines: Type BP3 Distribution By-Pass Switches

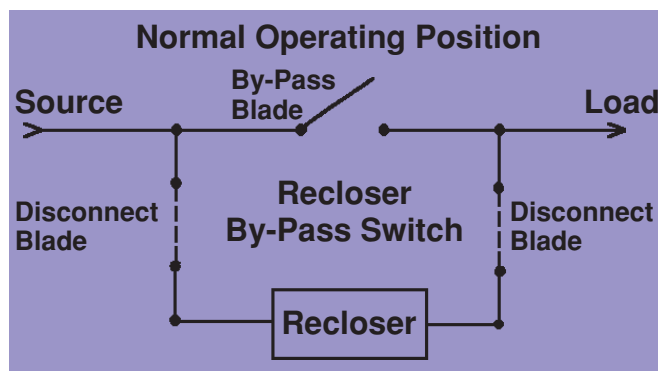
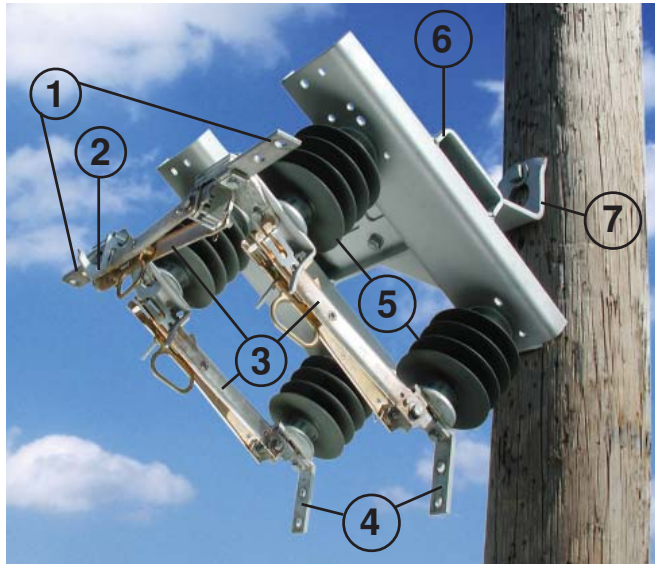

opened. Last, the M3S companion disconnect switch is opened to isolate the recloser from the circuit.

To restore service, close the recloser. Then close the M3S switch, followed by the disconnect blade on the BPF switch. In normal operation, the fuse holder is disconnected. Last, open and remove the fuse holder. ■

Continued . . .

Have it Your Way . . . BP3 Switch Components and Options

1. Terminal Pads (All)

Tin-plated high conductivity copper, NEMA two-hole terminal pad. Parallel Groove connectors (ATC1343) and captive hardware are available as options.

2. Loadbreak Hooks

Hot dipped galvanized steel hooks. To allow use of portable loadbreak tool. Provided on by-pass blade only.

3. By-Pass and Disconnect Blades

The by-pass and disconnect blades are of the same construction as those used on the M3 Hookstick Disconnect Switch. They are high conductivity copper blades, silver-plated at all contact areas. Stainless-steel back-up springs are used to maintain efficient current transfer between the stationary contact and the end of the blade. The by-pass blade is available in either right or left opening configurations (hinge on right or left).

4. Angled Terminal Pads

Angled construction allows for easier connection to a recloser while maintaining maximum pole clearance.

5. Insulators

ESPTM silicon alloy rubber, 2.25-inch bolt circle insulators.

6. Switch Base

Welded-construction galvanized steel base provides maximum rigidity to maintain consistent switch alignment for positive blade operation.

7. Pole Mounting Bracket

Single-piece galvanized steel mounting bracket facilitates ease of installation. A backstrap mounting option also is available.

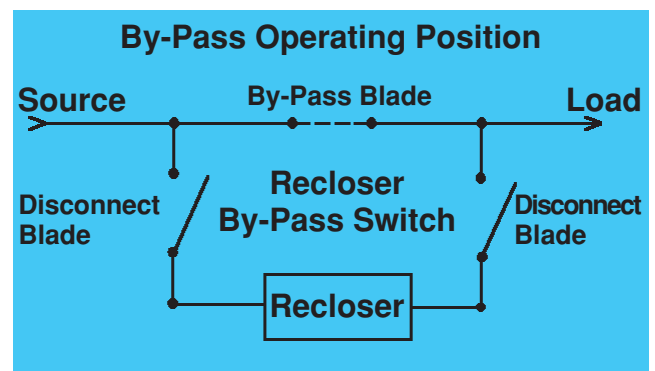

Performance Specifications

• 600 Amps Continuous • 65 kVA Peak Withstand

Max. Design, kV	Lightning Impulse Withstand Rating, kV	Leakage Distance, in.	Weight, lb.
17.1	110	17.2	56
29	125	21.9	62
29	150	28.2	65
38	150	28.2	65

For Substations: Type BPF Station-Class By-Pass Combination Switches

Have it Your Way . . .

BPF Switch Components and Options

1. Terminal Pads (All)

Tin-plated high-conductivity copper, NEMA two-hole terminal pad. Parallel Groove connectors (Cat. No. ATC1343) and captive hardware are available as options.

2. Loadbreak Hooks

Hot-dipped galvanized steel hooks are provided as standard on the disconnect blade and fuse mounting.

3. Disconnect Blade

The by-pass disconnect blade is of the same construction as that used on the M3 Hookstick Disconnect Switch. They are high-conductivity copper blades, silver-plated at all contact areas. Stainless-steel back-up springs are used to maintain efficient current transfer between the stationary contact and the end of the blade. See Chance USD Catalog Section 14B for further description.

4. Type C Cutout Fuse Holder

The same fuse holder used in Type C Cutouts, with a wealth of field operating history. Available in either 100 Amp or 200 Amp and mounting on the right- or left-hand side of the switch assembly.

5. Insulators

Insulators are ANSI/NEMA 3-inch bolt circle TR 205 or 208.

6. Mounting Base

Formed galvanized-steel base provides maximum rigidity and is designed for substation structure mounting.

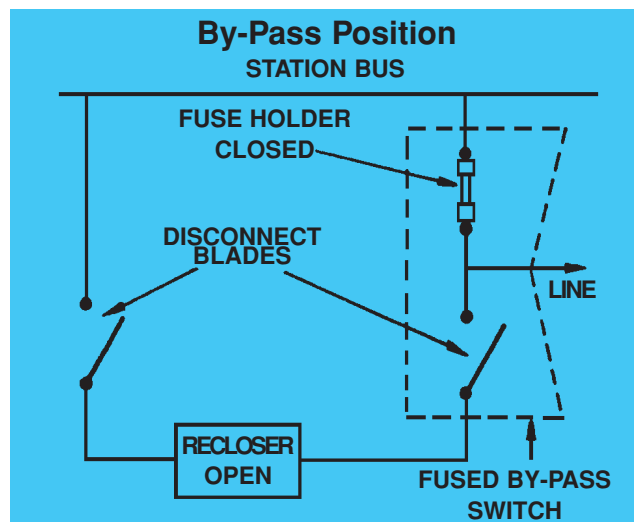
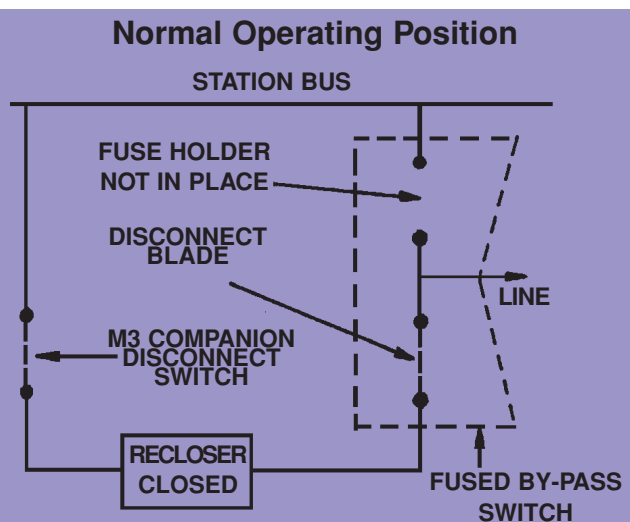
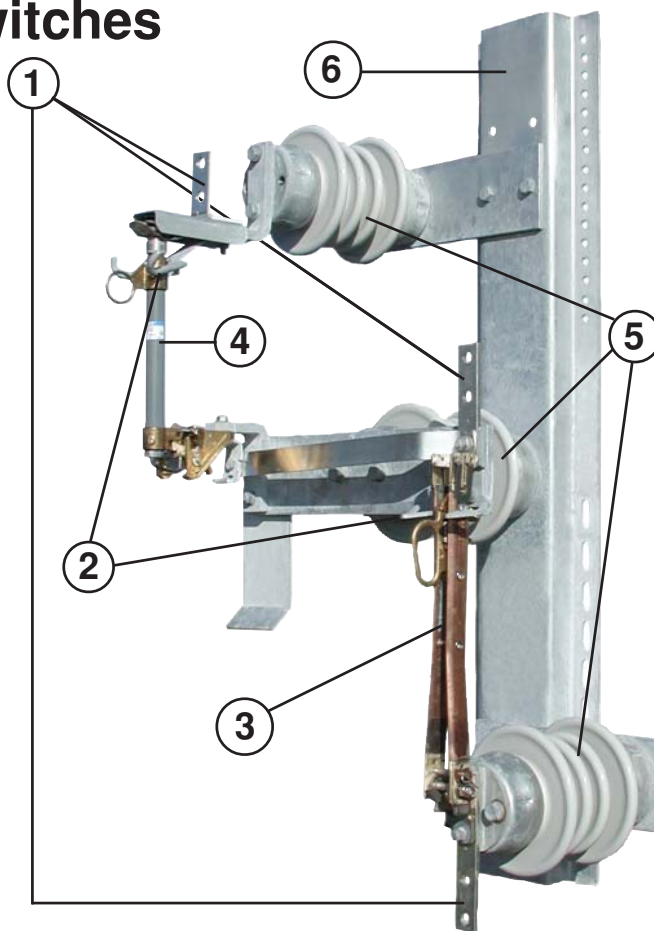

Performance Specifications

• 600 Amps Continuous • 65 kA Peak Withstand

Max. Design, kV	Fuse, Cont. Amps	Lightning Impulse Withstand Rating, kV	Interrupting Rating, kA asym.	3 in. Bolt Circle Insulator TR No.	Weight, lb.
15	100	110	10.0	205	125
15	200	110	12.0	205	125
27	100	150	8.0	208	140
27	200	150	10.0	208	140

For more information, contact your Hubbell Power Systems representative, fax 573-682-8714 or e-mail hpsliterature@hps.hubbell.com.



the
CATALOG ON THE WEB AT
http://www.hubbellpowersystems.com
Anderson, Fargo, Chance and
Ohio Brass Transmission Products

Go to our web site (hubbellpowersystems.com) and open the catalog icon to see our new transmission catalog. You'll see the complete Hubbell transmission products offering complete with products, drawings and ordering information, everything you need to quickly determine and fill your transmission product needs through one source, Hubbell.

From products for conductor support and protection to structure anchors, foundations, deadends and hot line tools, you can count on Hubbell to help you plan, construct and maintain your transmission lines.

We'll help you ensure the function and fit of a wide variety of transmission products that will work together to help you avoid construction glitches and maintenance problems later. And, you'll get delivery from one supplier without having to worry about coordinating multiple vendor deliveries to your construction schedule.

continued . . .



You'll cut costs with Hubbell transmission Products

Ohio Brass Protecta*Lite system virtually eliminates lightning - related breaker operations.



Ohio Brass EHV Insulation Systems



Anderson and Fargo Tower Connectors and Fittings



Chance anchors, foundations, deadends guy, support and secure structures



Look at the Hubbell Transmission Capabilities

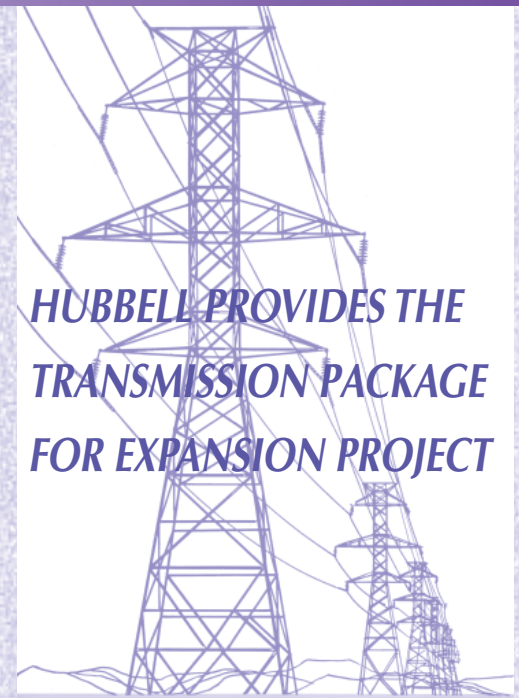

**HUBBELL PROVIDES THE
TRANSMISSION PACKAGE
FOR EXPANSION PROJECT**

By

Dave McDowell
Operations Engineer
Northwest Electric Power Cooperative
Cameron, Missouri

Products

Conductor Support

- Insulators
- Hardware
- Clamps
- Deadends

Conductor Protection

- Dampers
- Spacers

Lightning Protection

- Arresters
- Consulting Service

Structure

- Anchors
- Foundations
- Guy Deadends

Maintenance

- EHV Hot Line Tools
- Tool Training
- Grounding Systems

Reliability

- Financial Strength
- Responsibility Defined
- ISO Qualified
- Testing Facilities
- Large Commitment
- Experience
- Responsive

Savings

- One vendor
- One purchase order
- Cut procurement costs
- Lower bid price
- Components fit assured
- Coordinated delivery
- Quality

When Associated Electric put in a generator facility near Holden, Missouri it became our job to put in both a line and a substation that connects with the project. Although the total line length isn't much — just two miles, the key difference is that there are two transmission lines. We are going in with one line and coming out with another since the project involves 161kV circuits on top of the poles with 69kV "underbuilt" below on the pole.

For the line portion of the project we are using Chance anchors, Fargo compression transmission fittings for splices and deadends and Ohio Brass Hi*Lite® insulators. Anderson connectors, Fargo compression transmission fittings, and Ohio brass insulators and arresters are also used in the substation project.

We chose to use Hubbell products on the project because we are familiar with them since we use them on the rest of the system. The fact that they are interchangeable is a plus.

For more information, contact your Hubbell Power Systems representative, fax 573-682-8714 or e-mail hpscontact@hps.hubbell.com

AR SWITCH TURNS ON SAFETY AND SERVICE FOR IDAHO POWER

Hook-stick control is one key

Daron Beesley and Lewie O’Harra of Idaho Power Company’s Methods and Materials group are pleased with their choice of options on the newest type of

Hubbell unitized hot-stick-operated pole top switch.

The AR (Automation-Ready) Switch not only gives them the sectionalizing capabilities needed, but also affords practical control features to solve challenges posed by the locations and system situations.

Public access concerns

A traditional pole top switch has an operating handle mounted near the ground and is connected to the switch by a control rod. Although this configuration is convenient for the lineman, the handle is also

accessible to the public which increases exposure to accidental contact and the possibility of tampering. The first two AR Switches for Idaho Power were installed in rural agricultural settings where farm equipment could come into contact with the switch control handles.

System operation concerns

Because the 35kV line shared poles with an underbuilt 12.5kV line, a traditional pole top switch would require the operating controls to pass through the lower circuit. While not uncommon, that arrangement was not preferred.

Another issue is that Idaho Power construction specifications, and those of many other utilities, require a labor intensive ground grid to be installed at the base of a pole with a traditional type switch.

AR option delivers all solutions

By design, a single AR Switch option was available to fill all of these needs for Idaho Power. The unique optional hook stick control furnished an elegant

solution for this set of application challenges. It replaced the traditional control rod and handle that could have been inadvertently damaged by passing equipment or operated by unauthorized personnel. It avoided any need for extra clearance from the underbuild.

The AR – a switch for all the right reasons

Another benefit was faster installation because no adjustments to the control mechanism were needed, no ground grid was installed, and only two holes were drilled in the pole because no crossarm braces

At left, to prepare for this installation, Lineman Bill Schmahl has assembled extension links and Ohio Brass PDI™ Deadend Insulators to the AR Switch base for offset mounting.



Lockout/tagout now a standard feature

PATENT PENDING

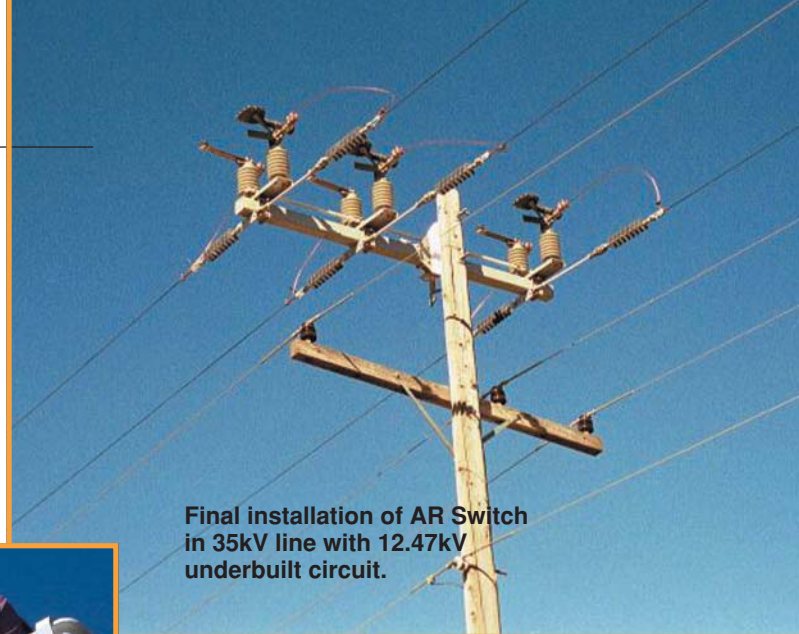

Final installation of AR Switch in 35kV line with 12.47kV underbuilt circuit.



Foreman Cary Darling positions switch for mounting.

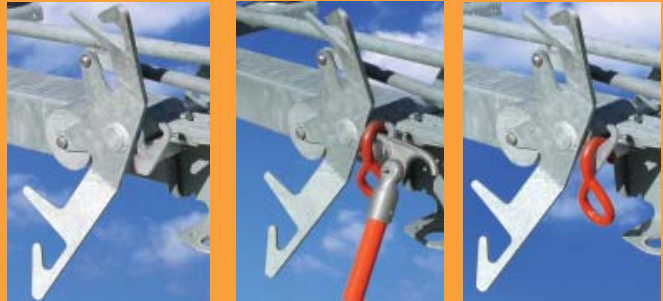

Provision on Horizontal and Delta Mounting AR Switches

The AR Switch hook stick control requires the least torque in the industry to open and close.

To provide for a lock/tag (such as the red lockout hook in these pictures), a standard feature now has been added to all configurations of the AR Switch. Conveniently located near the overtoggle operating mechanism, the lockout/tagout provision makes it easy to comply with individual utility standard practices for such procedures.

Hook stick and lock/tag are not included with Switches.

Phase-over-Phase AR Switch Mounting



Vertical AR Switch Mounting



were required. Although Idaho Power selected an AR Switch to meet the needs of these specific applications, AR Switches also have standard features that meet all of their unitized three-phase distribution-switch requirements:

- Excellent sectionalizing (900-Amp interrupt rating)
- Exceptional ice-breaking (industry record $\frac{3}{4}$ "-ice open-and-close capability)
- Easy operation (industry's lowest torque requirement to open and close a switch of this kind). ■

For more information, contact your Hubbell Power Systems representative, fax 573-682-8714 or e-mail hpscontact@hps.hubbell.com.



Arrester favorably tested after seacoast installation

After about four years of service in salt spray contamination along Florida's seacoast, a PDV-100 Arrester was returned to the Ohio Brass Research Center for evaluation.

The standard 7.65kV MCOV arrester had been in service along a beach, about 400 feet from the water on a 12,470 volt distribution circuit. The circuit has been subjected to salt contamination damage during its service life. For example, the pole top transformers have stainless steel tanks to extend their life. The line construction calls for 35kV post insulators having enough leakage distance to withstand the salt contamination.

The arresters previously used were porcelain 9kV arresters with 18kV housing to gain enough leakage distance to withstand the salt contamination. With polymer-housed PDV arresters, a great deal of money is saved over the cost of the special 18kV porcelain-housed 9kV arresters.

The OB evaluation showed the condition of the arrester housing surface is in good condition. The weathersheds had some slight signs of crazing caused by the years of exposure to ultraviolet light but there was no evidence of erosion or tracking on the surface of the housing. The stainless steel end hardware showed signs of mild oxidation, due to the salt spray contaminate.

The isolator had not operated, and no sign of failure was evident. Standard electrical tests including RIV/ internal ionization, starting voltage 1 mA peak current, and 10kA discharge voltage were run. The unit produced a noise level of less than 5 μ V above background during the RIV test. The starting voltage was 10.97kV. An acceptable voltage for this arrester falls between the range of 9kV and 12kV. The 10kA discharge voltage of this arrester measured at 29.2kV. — the cataloged maximum discharge voltage for this arrester is 30kV.

All tests prove the PDV-100 arrester was still in good working condition after four years in a very harsh coastal environment. ■

For more information, contact your Hubbell Power Systems representative, fax 573-682-8714 or e-mail hpscontact@hps.hubbell.com.

GDW

2000 SERIES

PATENT PENDING



Use New Deadend on 2/0 ACSR Conductor

The new Fargo GDW-2000 series deadend has been widely accepted since introduction in March 2001. Customers are enjoying the cost savings due to reduced installation time along with the numerous improvements incorporated into the design. Dave Flaten of Xcel Energy asked Fargo if the new GDW-2010 accepts 2/0 6/1 ACSR conductor. The published range for the GDW-2010 is #4 - 2/0 AAC (.23 - .42 in.). This range evolved in the years following the initial design release in 1993. Many aluminum bolted deadends have a range from #4-2/0 ACSR, and it would be beneficial for the GDW-2010 to accommodate 2/0 ACSR to better compete with standard bolted designs.

2/0 ACSR is slightly larger in diameter than 2/0 AAC and the new GDW-2010 design is flexible enough to allow acceptable installation of a 2/0 ACSR conductor. 2/0 ACSR is also 2,950 lbs. higher in Rated Breaking Strength (RBS), another hurdle the new GDW overcomes.

Conductor was installed into 13 GDW-2010 samples and tensioned to failure achieving an average tensile load of 58.7% RBS. Typical bolted straight line deadend clamps will achieve an average of 45-50% RBS.

Utilities can now convert from bolted straight line dead ends to the new time saving GDW-2010 design. Please contact your local sales representative for a copy of the full test report. ■

Catalog Number	Conductor Size				Approximate Conductor O.D.	
	ACSR ASTM-B232	Alloy ASTM-B399	Aluminum ASTM-B231	Copper ASTM-B8&258	Min./Max (inches)	Min./Max (mm)
GDW-2010A	4 - 2/0	4 - 2/0	4 - 2/0	-	.23 - .45	5.8 - 11.4
GDW-2010*	4 - 2/0	4 - 2/0	4 - 2/0	4 - 2/0	.23 - .45	5.8 - 11.4
GDW-2040A	4 - 4/0	4 - 4/0	4 - 4/0	-	.23 - .5a7	5.8 - 14.5
GDW-2040*	4 - 4/0	4 - 4/0	4 - 4/0	4 - 3/0	.23a - .46	5.8 - 14.5
GDW-556A	4/0 - 556.6 18/1	4/0 - 559.5	4/0 - 600	-	.52 - .90	13 - 23
GDW-556*	4/0 - 556.6 18/1	4/0 - 559.5	4/0 - 600	250 - 600	.52 - .90	13 - 23
GDW-795A	4/0 - 795	4/0 - 927.2	4/0 - 900	-	.52 - 1.1	13 - 28

For more information, contact your Hubbell Power Systems representative, fax 573-682-8714 or e-mail hpscontact@hps.hubbell.com.

OUR EMERGENCY RESPONSE TEAM IS READY 24/7

Before disaster strikes, the Hubbell Team is ready to provide the products you need to quickly and efficiently restore power.

Emergency material stocks are regularly monitored. As storm warnings are posted, the Team monitors potential storms by satellite and projects landfall.

Carriers are alerted 48 hours prior to projected damaged and in transit products are expedited to delivery points before the storm hits.

Hubbell shipping, production, purchasing and factory management are placed "on call" as we gear up to back you. Critical product production levels are increased. Product volumes are coordinated with your local Hubbell distributor even to the point of reviewing key contact names and phone numbers at our central distribution center so there is direct contact with Hubbell team members who are expediting shipments.

Throughout the effort, we monitor estimated time of product arrival by satellite communications to

ensure you get what you need, where you need it, as expected.

Think of it! One trusted supplier. With the products and years of disaster response experience to quickly help you reconstruct your damaged system and restore customers.

From the ground up, it's Hubbell. Anchors to secure poles. The hardware, connectors and fittings you'll need to get lines back in service. Polymer insulators, switches and cutouts too. And the hot line tools, cover up and grounding equipment you need to maintain your system.

At Hubbell, we pull out all the stops to help you get the power back on and keep it on. Our emergency performance history is proven, quick, and thorough. That's Hubbell. ■

For more information, contact your Hubbell Power Systems representative, fax 573-682-8714 or e-mail hpscontact@hps.hubbell.com.

The 370,000 sq. ft. Hubbell Power Systems distribution warehouse is state-of-the-art.



Your One Stop for the Products You Need

Construction • Switching • Protection • Insulation • Tools • Connectors

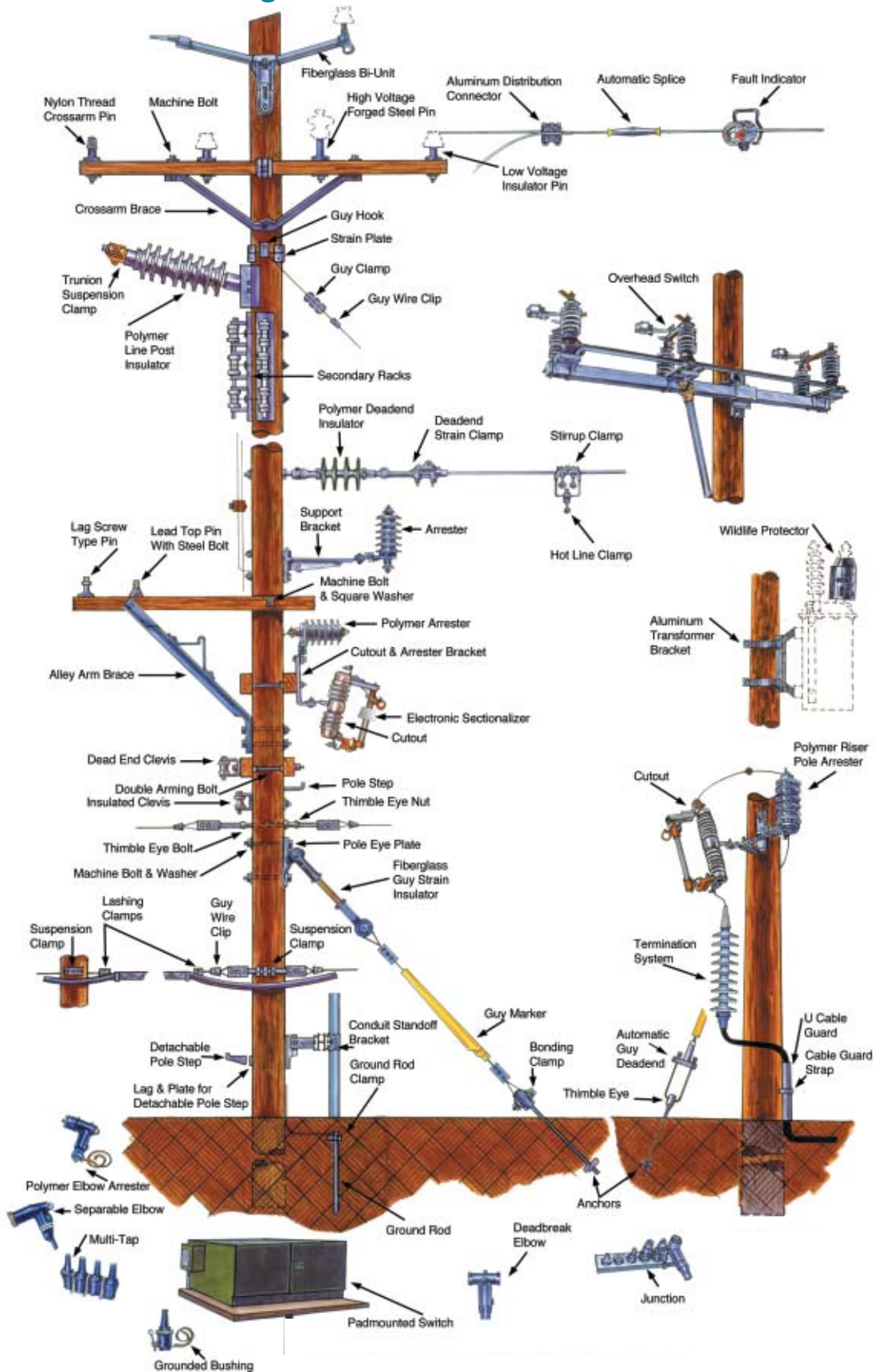

All-Angle Cog Wrenches

Handy hot line tools for hand-tightening only.

NOT for final torquing strain-related fasteners!

The proper tool to apply specified torque to line hardware is NOT an All-Angle Cog Wrench. It is an extremely handy insulated tool for “landing” a socket-wrench on energized hardware in unhandy locations, but it is not designed to tighten fasteners more than “hand tight.”

This makes it ideal for running nuts down on long bolts and uses that don't require higher torque such as mounting hardware for lightning arresters and static-ground assemblies not under strain conditions. It's rated for 15 ft.-lb. maximum torque.

Adjusts by hand on the spot

The wrench head's angle relative to the handle is adjustable in a 140° range. Wing nuts on both

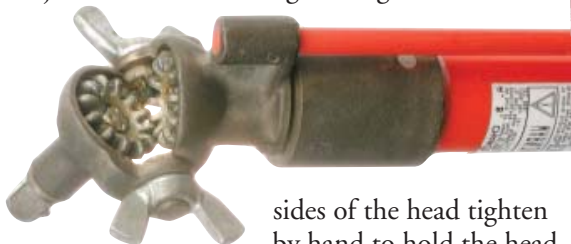

sides of the head tighten by hand to hold the head in a friction-locked position during use. This lets a line worker efficiently attain the angle needed to reach a fastener.

To start tightening, the hand grip steadies the tool and holds the cog head in place. Rotating the pole turns the cog gears to engage the wrench on the nut or bolt.

Sizes suited to various applications

All sizes of the All-Angle Cog Wrench feature a square shank to fit 1/2"-drive socket wrenches, an insulated handle of 1 1/2"-diameter foam-core fiberglass and a parallel control rod of 3/4"-diameter solid fiberglass. The hand grip is aluminum alloy, the cog housing is bronze alloy and the cog gears are hardened steel.

To provide live-line approach distances required for many system voltages, the All-Angle Cog Wrench is available in lengths of 6-, 8- and 10-feet. These easy-to-use tools weigh only 7, 7 1/2 and 8 lb. (3.2, 3.4, 3.6 kg).

Final torque-rated hot line tools

For a fastener started with an All-Angle Cog Wrench, use a higher torque-rated hot-line tool for final tightening.

Flexible Insulated Wrenches offer eight choices, including two lengths (6 and 8 feet) in two torque ratings (40 and 75 ft.-lb.). Each has a 1 1/2" fiberglass insulated shaft with a 1/2"-drive square shank on one end solidly joined to a universal joint. A coil spring over the fittings provides the right amount of flex control for a socket wrench on the end.

• **First, run the nut down the threads with an All-Angle Cog Wrench. Its adjustable tool head can easily get to hard-to reach fasteners.**



• **Second, finish the tightening with a Flexible Insulated Wrench (as at left) or a Ratchet (at right). For strain-carrying fasteners, these tools can develop the needed torque requirements.**



Three different fittings are offered for the other end of the shaft. One is a square socket for a 1/2"-drive ratchet and is used as an insulated extension to transmit torque to a socket wrench. It is available in both shaft lengths and torque ratings.

Two other styles come in only the 40 ft.-lb. rating. One has a universal head with a hole through its ferrule and shaft for a 5/8"-diameter turning rod. The rod (not furnished) is used as a handle to torque a socket wrench on the other end. This tool also doubles as a handle for the advantages of many universal tools.

The third style comes with a dedicated ratchet wrench solidly mounted in the shaft end, effectively giving the ratchet handle a long lever arm. The ratchet's reversible square shank fits 1/2"-drive socket wrenches.

From this wide selection of insulated tools, both speedy assembly and properly applying torque can be accomplished on energized lines. This includes tightening such strain-application hardware as dead ends, in-line dead ends, bolted hardware on deadends, down guys and span guy bolts. ■

New Overhead and Under sets help add worker safety

Temporary grounding sets specific to job needs

CHANCE® grounding clamps, ferrules and cable meet ASTM F 855.

When performing de-energized work on overhead or underground distribution, safety depends on proper temporary grounding. Were the circuit to become energized — by lightning, induction or error — the right precautionary grounding equipment properly applied could save lives.

We continue to add items to our temporary grounding line by working with utility maintenance personnel to provide just what they need. Here are some of the latest additions: *Completely pre-assembled sets ready to go on line per your application requirements.*



Overhead sets for your structure types

From our open stock of clamps, connectors and cable, you may specify any pre-assembled sets you require. Our pre-packaged kits were designed for use on these popular types of overhead structures:

- 7.2/12.5 kV A1 through C24
- 14.4/24.9 kV VA1 through VC9-3
- 46 kV TP1 through TP5
- 69 kV TS1 through TS3-2

For easy selection, these kits are cataloged by main line conductor sizes #2, 1/0, 2/0 and 4/0. Each kit includes five cables (three 6-ft. long, one 12-ft. and one 30-ft. long). The cables ends have crimped-on ferrules and

serrated-jaw C-type grounding clamps to fit conductors ranging from #8 to 1033 kcmil ACSR. Also included are a cluster support with a chain binder for pole mounting below the lineworkers and a 6-ft.-long copper-clad screw-in ground rod.

For easy placement of the phase-to-phase leads, a clamp-support stud is assembled to one of the clamps on each of the 6-ft. cables. By parking the lead's other clamp on it, the entire set can be lifted into position by a clampstick on just the clamp with the support stud.

An optional storage bag is available to hold any of these sets, except the grounding rod.

Underground sets for bushings & elbows

Bright orange elbows and bright yellow cable jackets instantly identify our temporary-grounding sets for underground switches and transformers. Single- and three-phase sets, plus replacement parts make up our complete line.

Recent additions are the three-phase grounded elbow set and single-phase grounded parking bushing sets shown here. Both are available for 15kV and 25kV applications and feature a bronze C-type grounding clamp and 1/0 copper grounding cable pre-assembled with appropriate connectors. A single-phase grounded elbow set also is available for 15, 25 and 35kV.



Replacement parts include orange elbows with probes for the three voltage classes above and bi-metal connectors for #2 and 1/0 grounding cable. ■

For more information, contact your Hubbell Power Systems representative, fax 573-682-8714 or e-mail hpscontact@hps.hubbell.com.

Added Safety for Linemen SafeOp™ Tap Plug Protects Workers

SafeOp™ Tap Plug provides a visual ground during repair or change out thus giving added visual security to linemen.



The SafeOp™ Tap Plug does more than just reduce a 600 amp deadbreak interface to a 200 amp loadbreak interface. A 1/2" copper bus joins the main body of a Loadbreak Reducing Tap Plug (LRTP) to a standard ANSI 200 amp loadbreak bushing well interface that is molded into and part of the tap plug.

Through the use of the SafeOp™ Bushing Well Interface, a grounding elbow never has to be removed. The elbow stays on during isolation and remains part of the cable circuit until work is completed and the unit is ready to be reconnected. This gives an added level of safety during de-energization. ■

For more information, contact your Hubbell Power Systems representative, fax 573-682-8714 or e-mail hpscontact@hps.hubbell.com

NOTE: Because we have a policy of continuous product improvement, we reserve the right to change design and specifications without notice.

Vol. 7 No. 2

AUG 2002

Hubbell TIPS & NEWS magazine is published to inform personnel of electric utilities and associated companies of new ideas and techniques in transmission and distribution practices. The magazine, under different titles and formats, has been published since 1932.

Your suggestions and editorial or photographic contributions are invited and may be submitted to **Hubbell TIPS & NEWS**.

HUBBELL TIPS & NEWS

210 N. Allen Street
Centralia, MO 65240-1395 USA

ADDRESS SERVICE REQUESTED

PRSR STD
U.S. POSTAGE PAID

HUBBELL

visit <http://www.hubbellpowersystems.com>



ANDERSON CHANCE® FARGO® HUBBELL® OHIO/BRASS®

UNITED STATES • 210 N. Allen • Centralia, MO 65240 • Phone: 573-682-5521 • Fax: 573-682-8714 • e-mail: hpscontact@hps.hubbell.com
 CANADA • 870 Brock Road South • Pickering, Ontario L1W 1Z8 • Phone: 905-839-1138 • Fax: 905-831-6353 • e-mail: infohps@hubbellonline.com
 MEXICO • Av. Coyoacan No. 1051 • Col. Del Valle • 03100 Mexico, D.F. • Phone: 52-55-9151-9999 • Fax: 52-55-9151-9988 • e-mail: vtasdf@hubbell.com.mx
 EUROPE • Ronald Close Woburn Rd. Indust. Est. • Kempston, Bedford • MK42 7SH, England • Phone: 44-1-234-843632 • Fax: 44-1-234-841435 • jhopwood1@aol.com
 ASIA • 23 Tagore Lane #03-16 • Tagore 23 Warehouse • Singapore 787601 • Phone: 65-6454-4772 • Fax: 65-6454-4775 • e-mail: hpscontact@hps.hubbell.com